

SAE Technical Paper Series

871042

Design and Development of the Voyager 200/300 Liquid Cooled Aircraft Engine

R. E. Wilkinson

Teledyne Continental
Aircraft Products Div.

**General Aviation Aircraft
Meeting and Exposition
Wichita, Kansas
April 28-30, 1987**

Design and Development of the Voyager 200/300 Liquid Cooled Aircraft Engine

R. E. Wilkinson

Teledyne Continental
Aircraft Products Div.

ABSTRACT

For well over 40 years, general aviation aircraft have depended almost entirely upon the air cooled horizontally opposed piston engine as the primary means of propulsion. Although a dependable powerplant, this type of engine has seen little change over nearly half a century of usage. To meet the challenge of future general aviation requirements, a new liquid cooled version of the horizontally opposed internal combustion aircraft engine has been developed by the Teledyne Continental Motors Aircraft Products Division. The Voyager engine is a liquid cooled high performance powerplant incorporating a patented lightweight liquid cooled cylinder assembly which provides improved cooling, reduced cooling drag, lower fuel consumption, better wear characteristics, longer life and TBO, and higher altitude capability. This paper presents the detail design of the liquid cooled 4.06 inch bore high compression ratio engine with emphasis on the unique design features and reviews the results of a comprehensive test and development program which has accumulated well over 5500 hours test time to date.

The Voyager 200 is a four cylinder liquid cooled 200 cubic inch engine with a 4.06" bore capable of producing 110 BHP at 2750 RPM with a high turbulence HTCC combustion chamber at 11.4:1 CR for minimum fuel consumption. This engine has already made aviation history by powering the Voyager aircraft on the historic record breaking non-refueled, nonstop flight around the world in late 1986. A six cylinder 300 cubic inch version utilizes the same cylinder assembly and is capable of being rated at 170-190 BHP at 2700-3000 RPM. Both engines are capable of providing a .375 BSFC across a broad operating range with minimal heat loss to coolant and oil. A brake thermal efficiency as high as 36% has been attained at lean cruise with specific heat loss to coolant and oil limited to only 16% of available fuel energy at best power mixture. A .345 BSFC has been demonstrated on the 300 cubic inch engine under conditions simulating advanced turbocharging techniques at high altitude.

Design and development of the 4.06 inch bore engine served as a technology demonstrator. The basic concept was validated and an experience base was established which will enable the development and introduction of a new family of aircraft piston engines capable of meeting the needs of future general aviation aircraft.

Beginning with the first flight of the Wright Brothers in 1903, liquid cooled piston engines have been used to power man's flying machines. The Wright Flyer was powered with an inline four cylinder 200 cubic inch liquid cooled engine which developed 12-16 HP at 1090 RPM. This was the first engine to propel man into the air in a heavier than air flying machine. Since that time liquid cooled engines have played a major role in aviation with many of the aircraft developed in the early 1900's and later in World War II powered by liquid cooled engines of a variety of configurations.

Liquid cooled engine configurations can basically be categorized as either separate cylinder or cast block. As implied by the name, separate cylinder involves engine designs where the cylinders are independent units, each individually cooled and detachable from the crankcase. Cast block engines are quite the opposite; all of the cylinders are an integral part of the crankcase with only the head structure being detachable. These two basic types are further classified as to cylinder orientation - inline, opposed, radial, vee, "H", and "W".

Separate cylinder liquid cooled engines were widely used during the early years of aviation history. Every German aircraft engine built in World War I utilized a separate cylinder construction, most notably the Austro Daimler inline six cylinder which was ultimately used as a pattern by other countries (1)*. Two of the most famous early American engines of this type were the Curtiss V-8 OX-5 and the Liberty V-12 (Figures 1 and 2, courtesy National Air and Space Museum). The British Rolls Royce Eagle V-12 was another notable example. The separate cylinder approach simplifies maintenance because disassembly of the entire engine is not necessary in order to correct a problem isolated to one cylinder.

*Numbers in parentheses designate references at end of paper.

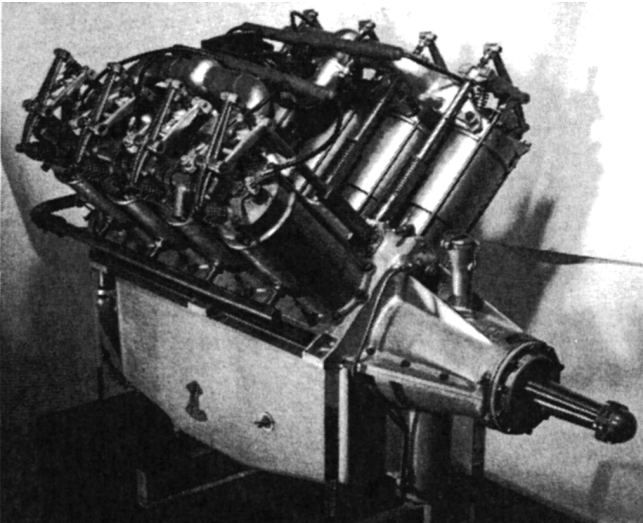

Fig. 1 - Curtiss V-8 OX-5, Early Separate Cylinder Liquid Cooled Engine

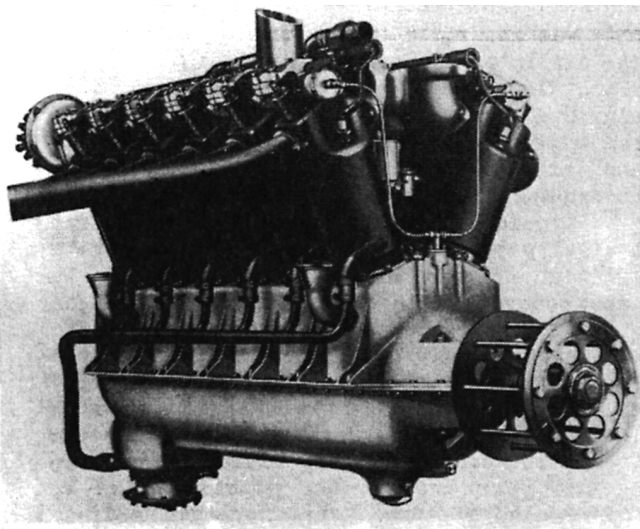

Fig. 2 - Liberty V-12, Early Separate Cylinder Liquid Cooled Engine

Cast block liquid cooled engines evolved somewhat later than the separate cylinder type and are probably better known due to their wide use in World War II. This type of construction offered reduced weight since it was possible to reduce cylinder spacing and effectively stiffen the crankcase structure. One of the less remembered but historically significant American engines of this type was the Curtiss Conqueror V-12. The U.S. Army Air Corp began a total changeover to radial air cooled engines in 1934 following an unsuccessful attempt to develop the Conqueror to operate with a 300°F coolant temperature (1).

The liquid cooled aircraft engine probably reached its zenith in World War II with the high performance cast block twelve cylinder "V" engine widely used by both Great Britain and Germany. The Merlin V-12 was one of the most famous British engines and was used to power the well known Spitfire in addition to the Lancaster, Wellington, and Halifax bombers. Most notable of the German liquid cooled power-plants was the Daimler-Benz DB-601 inverted V-12 which powered the ME-109. The Junkers 211, also an inverted V-12, powered the Stuka dive bomber. The only U.S. liquid cooled engine to see service in WWII was the 12

cylinder Allison V-1710 (Figure 3, courtesy National Air and Space Museum) which was used in fighters such as the P-51 Mustang and P-38 Lightning.

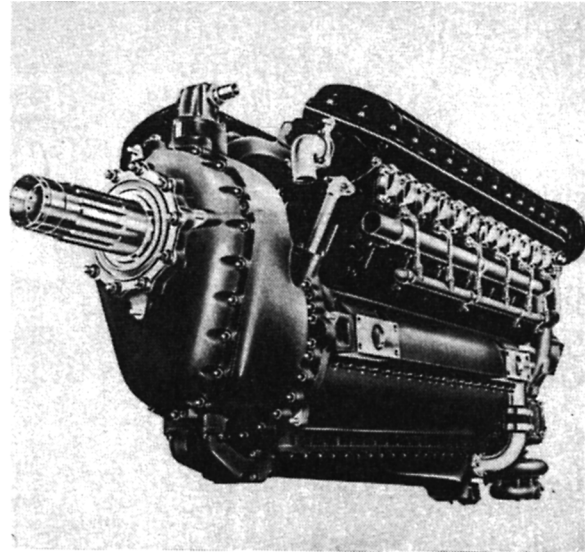

Fig. 3 - Allison V-1710, Cast Block Liquid Cooled Engine

Although liquid cooled engines were widely used both before and during WWII, the air cooled radial was applied in equal numbers, with the United States depending almost entirely upon the air cooled radial to power the majority of its military aircraft in WWII. The argument between air cooled and liquid cooled proponents raged during this time period. It has been said that adoption of air cooling offered a potential 25 percent reduction in forced landings attributed to coolant plumbing failures (1). It was also argued that the air cooled engine was more tolerant to combat damage. Other arguments centered around weight, performance, reliability, and cooling drag differences. Nevertheless, both types were widely used and apparently achieved acceptable reliability levels.

At the end of WWII, piston engine technology had been developed to a high level of perfection in both liquid cooled and air cooled configurations. Specific output had reached an almost unbelievable level with a reliability consistent with the demands of those difficult years. The war ended with some of the most powerful aircraft piston engines ever under development, such as the liquid cooled 2240 cubic inch Napier Sabre "H" engine with 24 cylinders at 2400 BHP. The ultimate was the Napier Nomad, a diesel turbocompound engine, which is one of the most fuel efficient aircraft engines developed to date with a cruise SFC of .330 LBS/ESH/HR. The interest in the efficient turbocompound cycle continued with the introduction of the air cooled Wright turbo-cyclone 18 cylinder that developed 3700 HP from 3350 cu.in. with a .380 BSFC.

However, in the post WWII era, the high technology developed earlier for the internal combustion engine became academic as the large high HP piston engine succumbed to the gas turbine for both military and commercial aviation. On the other hand, the civilian light airplane market flourished in the post war years, and the air cooled horizontally opposed piston

engine expanded rapidly to become the mainstay of what has become known today as general aviation. Although lacking the sophistication and specific output of the larger WWII engine, the horizontally opposed air cooled engine has gained the respectable reputation as a most dependable powerplant and has seen little change over almost half a century of usage.

To meet the challenge of future aviation requirements, a new liquid cooled version of the horizontally opposed engine has been developed. This new concept in liquid cooling utilizes individually cooled cylinders but with a unique lightweight approach to cooling the lower barrel section. High integrity aerospace type connectors are used at the coolant manifold joints to preclude the leakage problems which plagued the liquid cooled engines of the past. A lightweight, highly efficient coolant heat exchanger will be utilized to minimize aircraft cooling drag. An advanced technology combustion chamber is incorporated on the 200 and 300 cubic inch versions. BSFC levels approach the best developed by the larger sophisticated engines. For economical reasons, the bottom end remains relatively unchanged and is common to the air cooled predecessor.

Thus this new engine concept not only incorporates new ideas and advanced technology but also reflects features such as liquid cooling and separate cylinder construction, proven aircraft engine concepts, which date back to the earlier years of aviation. It shares much in common with both past and present aircraft engines but yet represents an advanced engine concept, applicable to both general aviation and non-commercial applications such as long endurance remotely piloted vehicles.

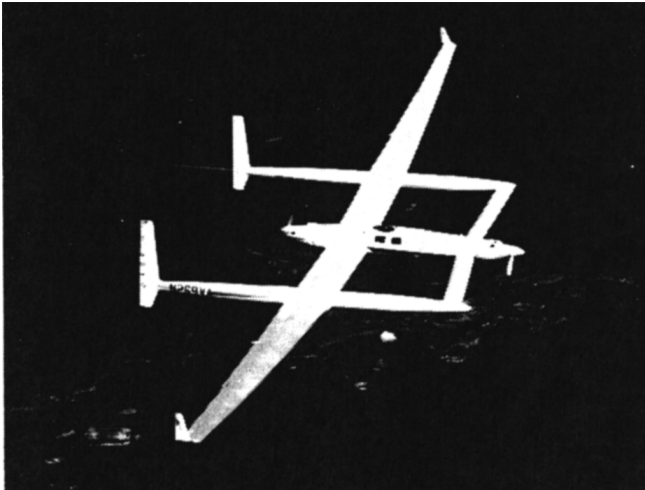

Fig. 4 - Voyager Aircraft, Powered by Liquid Cooled 200 Cu. In. Engine

This new family of liquid cooled engines has been named the Voyager series in honor of the first flight application of the 200 cubic inch version which powered the Voyager aircraft on the historic record breaking non-refueled, nonstop nine day flight around the world in late 1986 (Figure 4). In addition to the four cylinder 200 cubic inch engine, the line will include the six cylinder Voyager 300 using a common cylinder assembly and rated at 170-190 BHP. The Voyager 550, currently in a development stage, will be

rated at 300 HP naturally aspirated with a non-g geared turbocharger model rated to 350 HP and a geared turbocharged version available from 375-450 HP. Although not currently in development, 360 and 470 cubic inch versions are practical.

This paper presents the detail design of the 4.06 inch bore X 3.88 inch stroke liquid cooled engine and the results of a comprehensive test and development program performed on 200 cubic inch and 300 cubic inch versions which are considered the forerunners to a new family of liquid cooled aircraft engines.

ENGINE DESCRIPTION

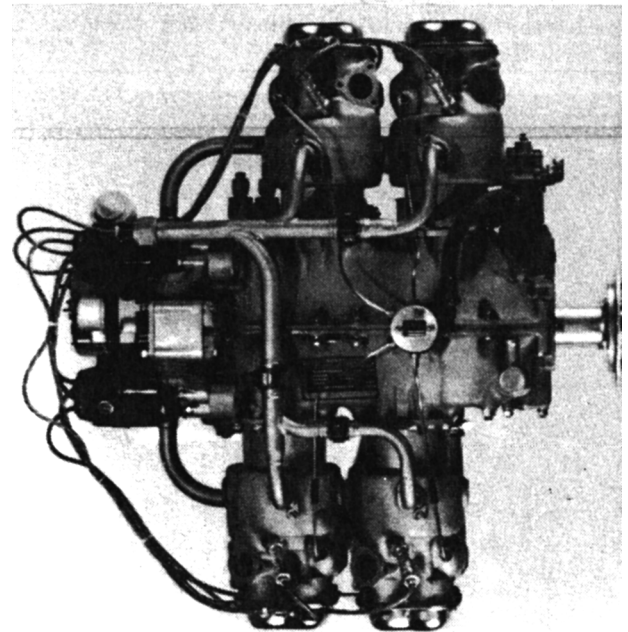
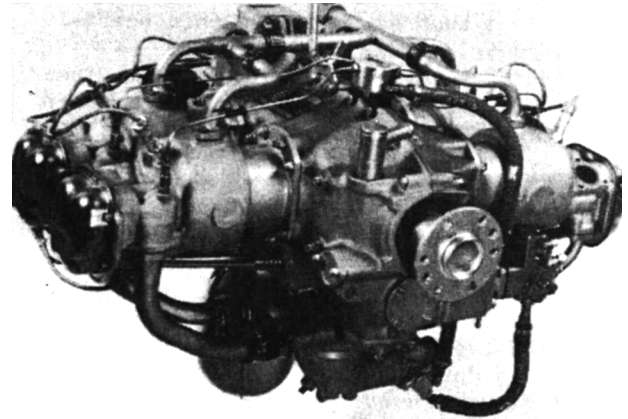

Fig. 5 - Liquid Cooled Voyager 200 Engine

The Voyager 200, as shown in Figure 5, is a four cylinder liquid cooled, horizontally opposed, four stroke, spark ignition, fuel injected aircraft engine capable of producing 110 BHP at 2750 RPM using 100LL aviation gasoline. This engine, also identified as a model IOL-200, is a highly modified liquid cooled version of the Continental model O-200, of which more than 25,000 units have been produced. The IOL-200 incorporates a patented lightweight cylinder design with a high turbulence combustion chamber (HTCC) operating at 11.4:1 compression ratio for minimum fuel consump-

tion. The engine is capable of providing a .375 BSFC across a broad operating range with minimum heat loss to coolant and oil. A conventional continuous flow fuel injection system is utilized; a fuel injector nozzle located in each intake port injects fuel directly into the oncoming charge airflow. The bottom end of the engine (crankcase, crankshaft, internal gearing) remains relatively unchanged and common to current production hardware.

The six cylinder 300 cubic inch version shown in Figure 6 utilizes the same cylinder assembly with a common bore and stroke at 11.4:1 CR with a standard production crankcase assembly. This engine, a model IOL-300, can be rated at 170-190 BHP at 2700-3000 RPM. Cruise fuel consumption is outstanding with values less than .375 BSFC obtainable with turbocharging at altitude. A .345 BSFC was demonstrated at 1600 RPM, 71 BHP during development testing with simulated advanced turbocharging at high altitude. Further refinements incorporated in the cylinder bore reduce oil consumption significantly. Each engine is equipped with a high performance, lightweight centrifugal coolant pump, gear driven on the rear accessory case. Lightweight integral coolant manifolds are included. Maximum allowable coolant inlet temperature is 250°F using a 60% aqueous ethylene glycol solution (AEGS). With a well designed coolant heat exchanger and proper installation, a significant reduction in cooling drag is possible. Maximum allowable engine oil inlet temperature is 250°F using a multi-viscosity 20W50 grade synthetic oil.

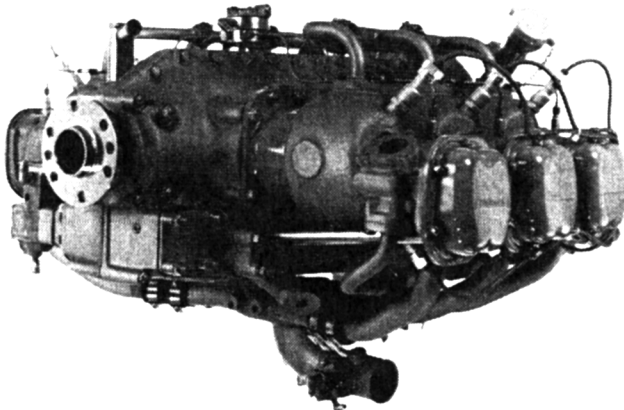

Fig. 6 - Liquid Cooled Voyager 300 Engine

Dry weight of the basic IOL-200 engine configured with intake manifold, fuel system, coolant pump and manifolds, magneto ignition system, spark plugs, and oil sump, but excluding alternator, starter, and exhaust manifold is 205 lbs. Equivalent dry weight of the IOL-300 is 304 lbs.

Unique design features of the Voyager 200 and 300 engines as compared to the air cooled 0-200 and 0-300 predecessors are summarized as follows.

- Liquid cooled power sections with integral water jacket and a partially cooled barrel.
- HTCC combustion chamber with 11.4:1 compression ratio.

- Parallel flow coolant system with tubular manifolds using high integrity aerospace type fluid connectors.
- Lightweight centrifugal coolant pump gear driven on rear accessory case.
- 60% aqueous ethylene glycol coolant and synthetic 20W50 lube oil.
- Crossflow cylinder head with refined intake and exhaust porting for improved flow.
- Minimum length exhaust port for reduced heat loss to coolant.
- Intake and exhaust manifolds designed for best volumetric efficiency.
- Oil cooled cast aluminum piston with a steel insert top ring groove for improved durability.
- High flow rate piston oil jet to supplement cooling of lower barrel section.
- Refined cylinder bore finish with a scraper type bottom ring for reduced oil consumption.

DESIGN APPROACH

Unlike conventional automobile engines where the cylinders are formed as an integral part of a single block type crankcase structure, air cooled horizontally opposed aircraft engines have utilized separate cylinders attached to the crankcase with threaded fasteners. Early in the liquid cooled engine design study, the decision was made to pursue a liquid cooled concept which would allow utilization of a bottom end, common to the existing production air cooled line. It was not considered economically practical to design a completely new engine.

The Voyager engine design concept meets these requirements by utilizing individually liquid cooled cylinders, similar to the separate cylinder construction adopted by many of the early liquid cooled aircraft engines. Each cylinder assembly is an independent unit attached to the crankcase, in the same manner as the air cooled cylinder. Figure 7 provides a comparison between the air cooled and liquid cooled 4.06 inch bore cylinder assemblies. A new design cast aluminum cylinder head with an integral water jacket is assembled to the cylinder barrel using the conventional long proven threaded interference fit type joint. The steel cylinder barrel is similar to its air cooled counterpart except cooling fins are deleted, and the pilot area is lengthened in order to accommodate the length of the cylinder head water jacket. Cooling of the lower barrel section is accomplished by a high flowrate piston oil jet as described in the following sections.

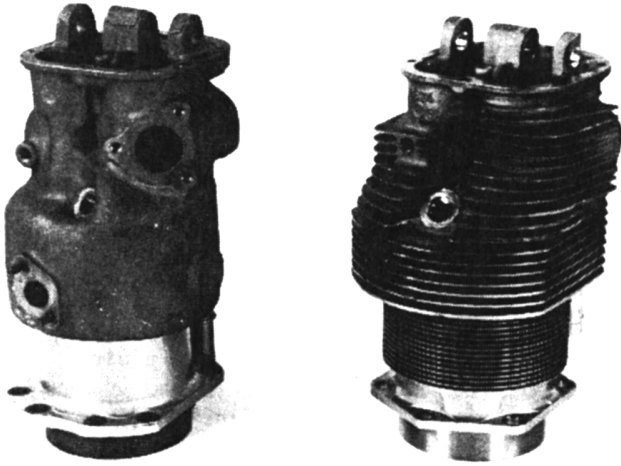

Fig. 7 - Comparison of Liquid Cooled and Air Cooled Cylinders

Parts such as rocker covers, rocker arms, valve springs, connecting rods, and piston pins remain common to the air cooled engine. Pushrods are lengthened due to the rocker area being displaced outboard with incorporation of the HTCC combustion chamber. New valves are provided and the piston is modified to accept an improved ring set with a steel insert in the top ring groove for enhanced durability. A parallel flow coolant circuit supplies coolant to each cylinder using a tubular manifold; connectors utilized at the intercylinder joints provide for cylinder relative motion and thermal growth.

This unique design concept offers an economical, lightweight, and effective means of providing a liquid cooled aircraft engine for general aviation. The approach is applicable to the entire air cooled aircraft engine product line and is compatible with existing manufacturing capabilities. The ease of maintenance is not compromised; disassembly of the entire engine is not required in order to perform maintenance on a single cylinder. The bottom end of the engine remains relatively unchanged, common to the existing air cooled production hardware. Large tooling costs as would normally be encountered with a totally new engine are avoided.

COOLING SYSTEM DESIGN

The Voyager 200 and 300 utilize a common liquid cooled cylinder assembly with a coolant jacket formed as an integral part of the cast aluminum cylinder head. This coolant jacket encircles the combustion chamber area and the outer end of the cylinder barrel. Unique to the design concept, the coolant jacket extends down along a portion of the cylinder length as illustrated in Figure 8, terminating at a position adjacent to the bottom of the piston skirt when at TDC. This leaves the lower length of the barrel free of the coolant jacket, thereby resulting in a lightweight but effective cooling system.

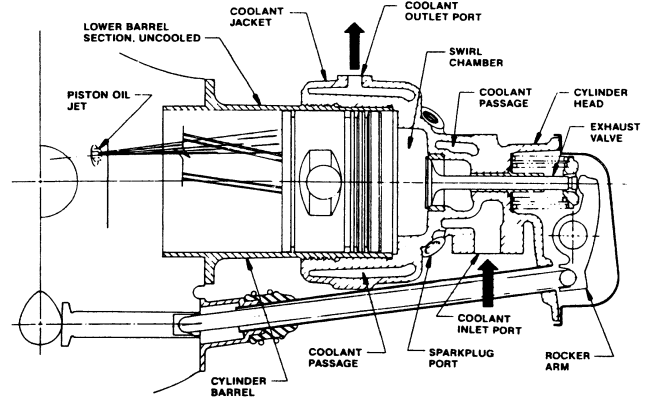

Fig. 8 - Design Approach, Liquid Cooled Cylinder Assembly

A coolant passageway, having an inlet and outlet port is formed within the cylinder head. An engine driven pump supplies coolant under pressure via an external manifold to a flanged inlet port located on the lower side of each head. Upon entering the head, the coolant is first directed through a central passage to the critical valve bridge area with a portion bypassed immediately around the exhaust port. The intake port is left free of direct cooling along with a small section of the exhaust port. Transfer passages direct the flow around the spark plug ports and valve seat areas, thence into the barrel coolant jacket to a flanged outlet port located on top vertical. The coolant is then collected in a manifold and directed to a ram air cooled heat exchanger.

As an integral feature of this system, the lower length of the cylinder barrel is not enclosed by the coolant jacket. Instead, it is cooled by the spray of an oil nozzle directed at the under side of the piston dome. This oil jet is the primary cooling mechanism for the piston and the lower barrel section. Piston oil jets are not uncommon on air cooled aircraft engines; however, a proportionately higher oil flowrate is used to indirectly cool the lower barrel. Referring to Figure 9, a schematic representing piston and cylinder heat balance is illustrated. Heat is transferred by conduction from the cylinder wall via piston rings and oil film to the cooled piston. In addition, a lesser amount of heat is conducted through the cylinder wall into the crankcase which is subsequently oil cooled.

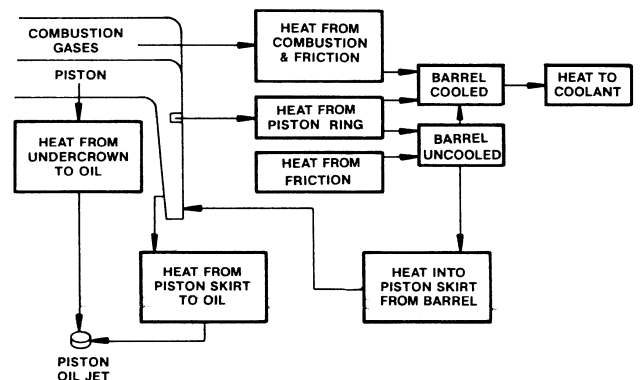

Fig. 9 - Piston/Cylinder Heat Balance

A major advantage of this design approach is that the cooling jacket extends only a relatively short distance along the cylinder, thus avoiding complication and minimizing weight. In practice, this concept has proven to be an effective means of controlling engine heat rejection. The resulting liquid cooled cylinder weighs less than the equivalent air cooled cylinder and provides improved uniformity of cooling in both combustion chamber and cylinder barrel - characteristics which contribute to improved durability and longer life.

COOLANT FLOWRATE AND TEMPERATURE

The maximum operating coolant temperature into the engine is 250°F with a 20°F rise across the engine at maximum power. By designing for a high coolant temperature rise, the coolant flowrate is reduced which minimizes pump power and size. The high coolant bulk temperature serves to lower heat rejection which helps minimize heat exchanger size and weight. Coolant flowrates for the IOL-200 and IOL-300 at maximum power are 13 GPM and 20 GPM, respectively, with the 20°F rise.

CYLINDER HEAD THERMAL LOADING

Experience has shown that the maximum metal temperature in combustion chambers using aluminum alloy should be limited to about 500°F for adequate durability. Typically, the valve bridge section is the most critical area for thermal loading. Metal temperatures were predicted using heat fluxes estimated from empirical correlations along with calculated liquid side heat transfer coefficients. Heat flux within the combustion chamber was assumed to be primarily a function of specific fueling -fuel flowrate/piston area. Peak heat fluxes within gasoline engines normally occur in the range of .074 - .077 fuel/air ratio, equivalent to best power mixture. Applying the predicted heat flux to a particular section of the flame deck, gas side metal temperatures were calculated using metal thermal conductivity, wall thickness, coolant bulk temperature, and liquid side heat transfer coefficient. Thermal loading within the cylinder assembly was modeled according to the following distribution.

Cylinder Head	34%
Exhaust Port	21%
Upper Barrel	19%
Lower Barrel	26%
	100%

PISTON/BARREL COOLING

Heat is removed from the piston by an oil jet which impinges on the undercrown and by conduction via the compression rings and oil film to the cooled barrel. The local heat flux into the cylinder barrel gas face arises from three sources.

1. Heat conducted from piston through compression rings.
2. Heat generated on running surface by piston and ring friction.
3. Direct heat transfer from combustion gases.

The cylinder barrel must be adequately cooled such that the gas side temperature is low enough to permit satisfactory lubrication of the piston/ring-to-barrel sliding interface. In addition, temperatures in the top compression ring groove must be limited to prevent carbon formation and ring sticking. Length of the cylinder barrel coolant jacket directly influences piston ring and skirt temperatures. Thus, there is a combination of piston oil cooling flow and coolant jacket length which maintains piston ring and skirt temperatures within allowable limits. Since most of the heat flux into the lower barrel is conducted directly from the piston, increasing the piston oil jet flowrate reduces the heat flux into the lower cylinder sufficiently to allow a partial coolant jacket on the cylinder barrel.

Referring to Figure 8, coolant jacket length on the 4.06 inch bore cylinder is only 2.5 inches as measured from the outer end of the barrel, covering approximately 67% of piston travel. An estimated proportioning of the cooling modes for the uncooled lower barrel section is shown as follows.

Piston Oil Squirt	83%
Conduction	14%
Convection	1%
Radiation	2%
	100%

THERMAL MAPPING

Thermal loading of the new design power section was evaluated by instrumenting a cylinder assembly with twenty-four thermocouples - eight each in combustion chamber dome, twelve each on cylinder barrel wall, two each in water jacket, and one each at cylinder flange and lower spark plug port. Dome thermocouples were positioned within .050 inches of the gas side wall. Two each of the cylinders instrumented as described were operated at No. 1 and No. 3 positions on an IOL-200 engine. Metal temperatures were then measured across the operating range, concentrating on the high power settings with maximum coolant and oil temperatures at both lean and best power mixture settings.

Results of the cylinder cooling evaluation were quite satisfactory with the combustion chamber and cylinder wall metal temperatures uniform and well within material limits, even with 290-300°F coolant at 110 BHP. The entire cylinder assembly was observed to operate at a more uniform temperature level from cylinder flange to combustion chamber. Figures 10 and 11 present typical thermal profiles for cylinder No. 1 at 110 BHP and 80 BHP, equivalent to 170 BHP and 120 BHP on the six cylinder 300 cubic inch engine. Thermal

maps for No. 3 cylinder were essentially identical, indicating no significant cylinder variations in cooling and fuel/air mixture. In comparison, cylinder cooling on the equivalent air cooled engine is typically less uniform and highly dependent on the installation.

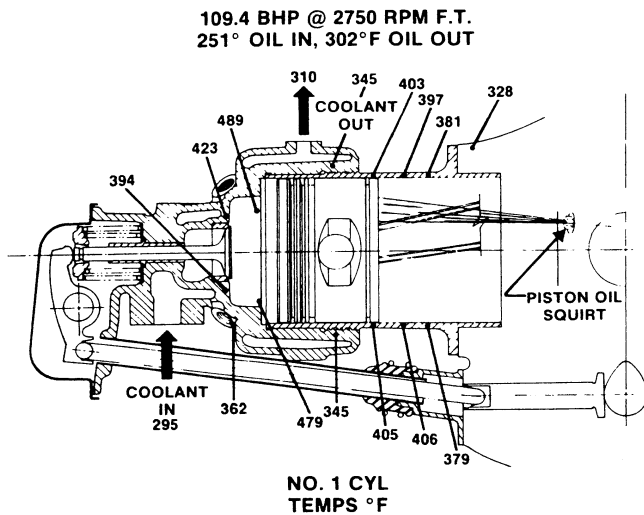

Fig. 10 - Cylinder Thermal MAP, IOL-200 at 109 BHP

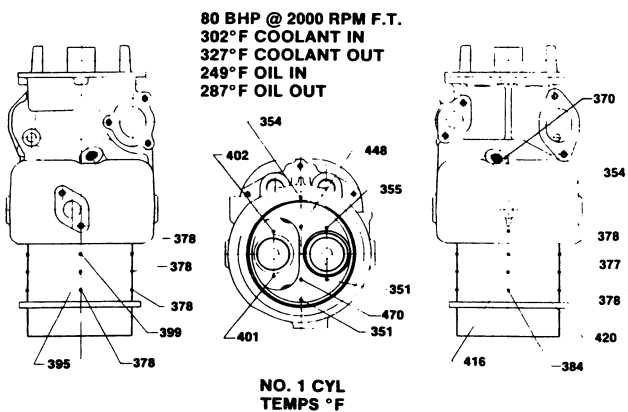

Fig. 11 - Cylinder Thermal MAP, IOL-200 at 80 BHP

Highest metal temperatures were obtained at 2750 RPM and 110 BHP. The valve bridge as expected, was the hottest area in the head at 489-512°F. Lowest metal temperature observed in the dome was 362-367°F, adjacent to the intake valve seat. This equates to a maximum differential in metal temperature of 145°F. Spark plug gasket temperatures were 363-390°F. Figure 12 illustrates the effect of coolant temperature on combustion chamber dome. It was concluded that the maximum metal temperatures are influenced primarily by power output with mixture and coolant temperatures having a second order effect. Cooling of the liquid cooled head was determined to be superior to the air cooled version in terms of both maximum temperatures and uniformity of cooling. Maximum valve bridge metal temperatures encountered in current air cooled aluminum cylinder heads can reach 600°F on the higher output production engines.

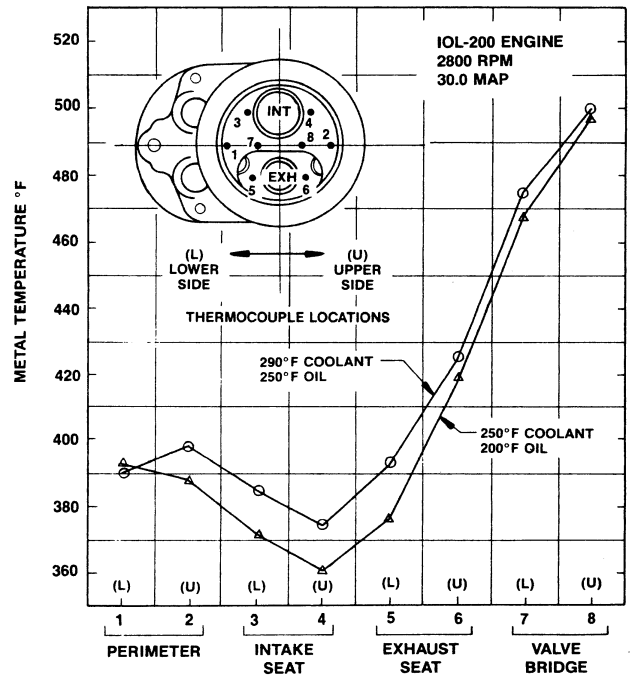

Fig. 12 - Effect of Coolant Temperature on Combustion Chamber Dome

Thermal testing of the piston using the fusible plug technique indicated the dome operates between 520°F and 580°F at max power, reflecting the effectiveness of the piston oil jet. The corresponding piston skirt temperatures were less than 430°F. Piston dome temperatures on typical air cooled aircraft engines have been shown to reach 620°F.

Exhaust valve temperature was investigated using the loss in hardness technique, which indicated a maximum value of 1407°F in the fillet radius of the underhead area. Average peripheral temperature was 1249°F with 1267°F max. Temperature gradients around the head were minimal, indicating adequate rotation. Test point was 2750 RPM, max power, with peak EGT mixture. These temperatures are well within acceptable limits.

COOLING CIRCUIT

Most automotive cooling systems utilize a series coolant flow circuit. Typical of these systems, coolant enters the block and flows first around the base of each cylinder before being directed to the cylinder head area. This approach tends to over cool the cooler bottom end and under cool the hotter head area with the cylinder heads increasing in temperature along the flow path as the coolant temperature rises. In a cooling system where the flow is first directed through the head area before circulating around the cylinder barrel section, a more uniform cylinder assembly temperature profile is possible. In addition, a parallel coolant circuit can provide a more uniform cylinder to cylinder temperature distribution since each cylinder sees essentially the same coolant temperature.

The cooling system on the Voyager 200 and 300 engines is arranged such that the coolant flows in parallel through the cylinders. By using a parallel rather

than a series flow system, the pressure drop through the engine is minimized. This loss has been measured at only 1-2 PSI. Pump power demand is reduced as compared to a series flow system.

As shown in Figures 5 and 6, coolant supply and return manifolds are of a tubular aluminum alloy construction. Consistent with aviation standards that apply to aircraft fuel and lubrication systems, all connectors and seals in the cooling system are high integrity designs that have evolved from aerospace experience in developing reliable fluid handling methods. Quick disconnect aerospace type couplings with O-rings are used at the intercylinder joints. A degree of flexibility is required at these joints to accommodate differential thermal expansion and cylinder motion under firing loads.

Engine coolant is a 60/40 mixture of ethylene glycol and water (distilled or de-ionized). Those coolant brands with aluminum corrosion inhibitors are recommended. Testing to date has shown no deposits within the flow passages. With the 250°F maximum allowable coolant inlet temperature to the engine, a 30 PSIA minimum pressure must be maintained at the coolant pump inlet to prevent boiling and cavitation.

HTCC COMBUSTION CHAMBER

The ultimate objective of the aircraft engine combustion system is best possible thermal efficiency and fuel economy, both directly influenced by efficiency of the combustion process and design of the combustion chamber. Developments over the past years have shown "fast burn" combustion chamber designs to be capable of achieving higher net thermal efficiencies with lessened cyclic variation and reduced knock tendency (2). Design features which promote fast burn in a combustion chamber are:

- Compact chamber design with short flame travel distance
- Minimum squish height (compression zone between flame deck and piston at TDC)
- Generation of chamber turbulence, swirl, and higher inlet port velocity
- Spark plug location and concentration of chamber volume around the ignition source
- Large surface to volume ratio in the end gas region

Squish is defined as the gas motion resulting from the compression of the gaseous mixture between that part of the piston closest to the combustion chamber dome or valves at TDC. Compact chamber designs are characterized by small squish heights and tend to yield a more rapid flame front with faster burn rates which has been shown to be an effective approach for reducing fuel consumption and octane requirements. Higher intake port velocities are used to promote turbulence which consequently improves combustion rate. Intake swirl has also been shown to enhance turbulence and reduce cyclic variability (3).

Research had indicated that while turbulence without swirl enhances combustion, turbulence with swirl

produces even faster burning and lower cyclic variability. Squish provides an effective approach for increasing combustion rates, especially during that time of the combustion event, when the piston is at TDC and effect of squish is strongest. Swirl and squish complement each other since swirl reaches its peak early in the combustion process, and squish reaches its maximum strength later as the piston approaches TDC. It is therefore important that a new combustion chamber design carefully address chamber geometry, intake port velocity, swirl, squish and spark plug location if higher combustion efficiencies are to be attained.

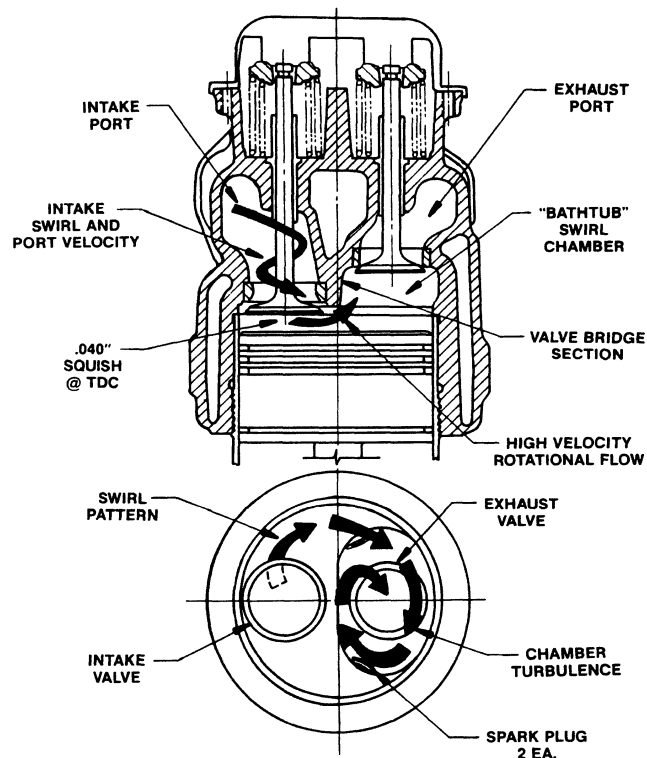

Fig. 13 - HTCC Combustion Chamber

The combustion system incorporated into the Voyager 200/300 engines is a compact fast burn high turbulence combustion chamber (HTCC) which operates at a 11.4:1 compression ratio. To promote swirl and turbulence of the fuel/air mixture, the exhaust valve is deeply recessed within a "bathtub" shaped chamber type depression as illustrated in Figure 13. The plane of the inlet valve is located in that portion of the cylinder head where the critical squish zone is created with the opposed flat piston dome. Nominal squish height is .040 inches. As the piston approaches TDC during the compression stroke, reaching minimum volume in the squish zone and maximum compression of the charge mixture, the high velocity rotational flow within the swirl ("bathtub") chamber is intensified, thus contributing to a more rapid and efficient combustion process. Past research into the effect of swirl chamber aspect ratio (length/depth) indicated minimum BSFC is obtained between 3.5 and 4.0 (4). Aspect ratio for the HTCC swirl chamber is 3.7. Twin spark plugs are positioned in the swirl chamber as shown in Figure 13. The intake port size and geometry was designed con-

sistent with the swirl and inlet port velocities required for efficient combustion.

With HTCC, the Voyager 200 and 300 engines have achieved up to 20 percent better fuel economy and 10 percent higher horsepower as compared to the air cooled counterparts at 7:1 compression ratio. Brake thermal efficiencies as high as 36% have been attained naturally aspirated. A 39% brake thermal efficiency has been demonstrated on the 300 cu. in. engine with reduced exhaust back pressure simulating the effect of higher efficiency turbochargers at altitude. Knock characteristics for the naturally aspirated IOL-200 and IOL-300 engines with conventional 100LL aviation gasoline are considered satisfactory. However, the use of turbocharging which results in higher inlet air temperatures to the engine may require an operational strategy such as spark retard and/or reduced manifold pressure to maintain adequate knock margins.

CYLINDER FIRING PRESSURE

Peak cylinder combustion pressures were evaluated under a wide range of operating conditions. At 2750 RPM with 30.0 in. Hg. ABS. manifold pressure, peak cylinder firing pressures vary from 975 PSI at 18°BTDC ignition timing to 1125 PSI at 30°BTDC ignition timing. Cylinder pressure characteristics were investigated as a function of such variables as engine speed, manifold pressure, ignition timing, fuel/air ratio, and inlet air temperatures. Peak cylinder pressure is largely a function of inlet manifold pressure and is a maximum at wide open throttle. For the naturally aspirated Voyager 200/300 engines, peak pressure is approximately 1100 PSI when operating at 2000-2750 RPM WOT. The combustion pressure wave forms are regular and indicative of proper combustion with no significant variation among the various cylinders. Figure 14 represents a typical HTCC pressure diagram.

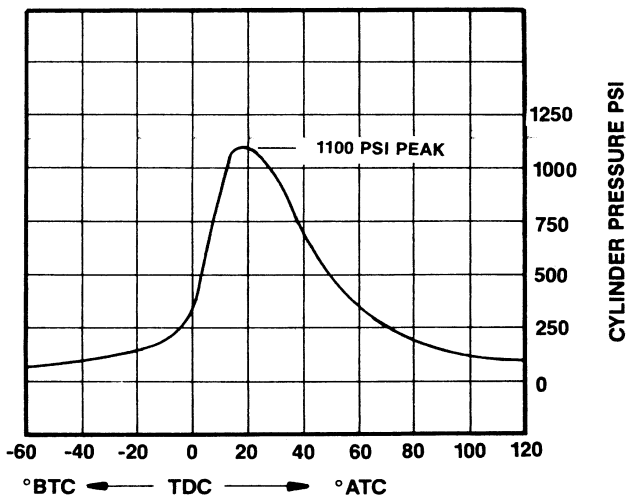

Fig. 14 - Cylinder Pressure Diagram, IOL200 @ 2750 RPM, WOT

HEAT REJECTION

Internal combustion engine heat rejection characteristics are best evaluated on the basis of three qualitative parameters defined as follows.

1. Percent of available fuel energy lost to cooling.
2. Heat lost to coolant and oil as a percentage of engine BHP output.
3. Specific heat loss defined as ratio of cooling heat load to engine BHP (BTU/Min/BHP).

Naturally aspirated liquid cooled automotive gasoline engines typically reject 20-25% of available fuel energy to cooling. The best high performance automotive engines dissipate as little as 16% at maximum power. Typical specific heat rejection values for automobile engines vary from 30-40 BTU/Min/BHP depending upon output. In comparison, the high specific output liquid cooled engines of World War II were far more efficient with specific rates as low as 15 BTU/Min/BHP with less than 10% of total fuel energy lost to cooling.

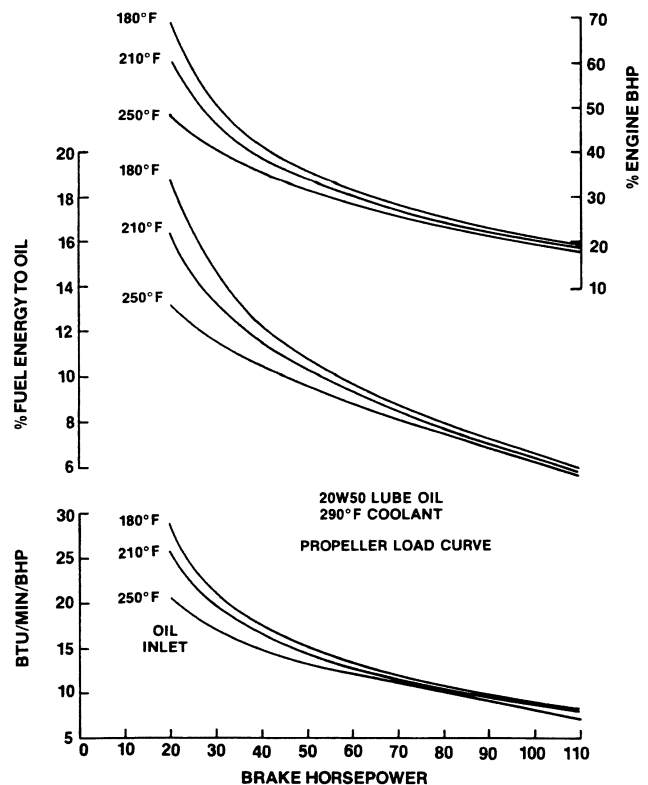

Fig. 15 - IOL200 Specific Heat Rejection to Oil

Heat rejection characteristics for the IOL-200 engine at sea level ambient conditions operating on a propeller load curve with best power mixture are presented in Figures 15 and 16. The effect of higher coolant temperature is clearly apparent. A 40°F increase from 250°F to 290°F offers a potential 10% reduction in heat loss which would reduce the size of the coolant to air heat exchanger. Although the engine thermal loading and heat loss characteristics were evaluated with 290°F coolant, the maximum allowable inlet temperature to the engine is restricted to 250°F. This de-

cision was made in consideration of the lack of test experience at the elevated temperature and the potential problems associated with the higher pressures (45 PSIA minimum) required to prevent boiling and cavitation. The oil heat rejection figures are somewhat higher than other similar engines due to the larger oil flow rates used for cooling of the lower barrel section. Since the combined coolant and oil heat loss remain well within limits, the design approach is considered quite adequate.

**Table 1 - IOL-200 Heat Rejection Summary
250°F Coolant, 250°F Oil**

BHP	BTU/MIN	BTU/MIN/BHP	% FUEL ENERGY	% BHP
110	2475	22.5	16.8	53.0
80	2136	26.7	19.7	62.5
60	1812	30.2	21.9	71.0
40	1440	36.0	25.0	84.0
20	980	49.0	30.6	115.5

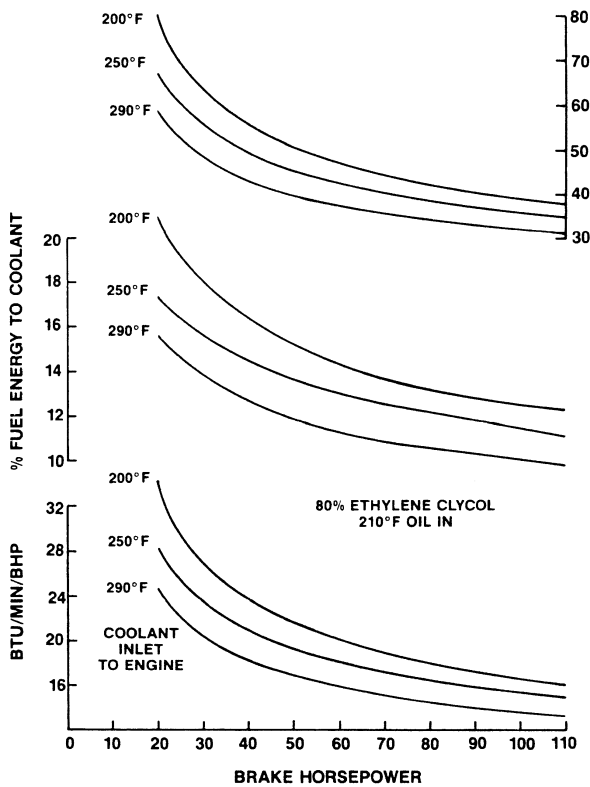

Fig. 16 - IOL200 Specific Heat Rejection to Coolant

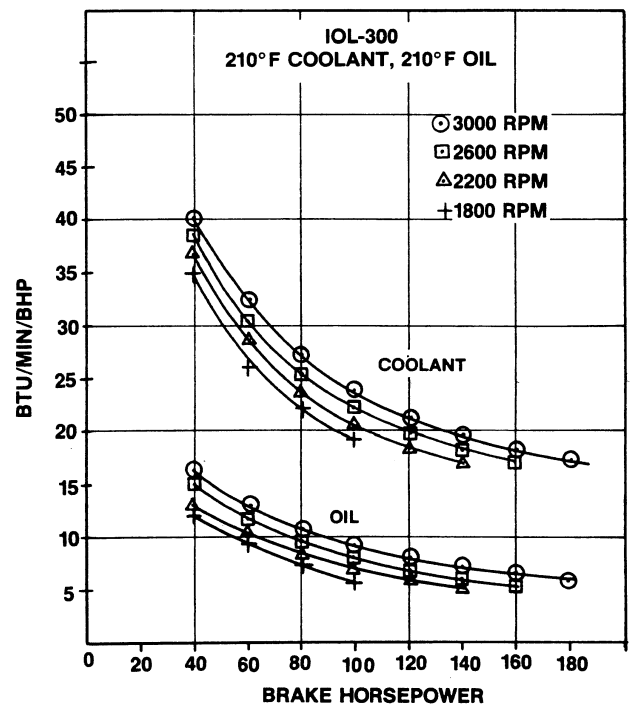

Fig. 17 - IOL300 Specific Heat Rejection to Coolant and Oil

Table 2 - IOL-300 Heat Rejection At WOT 250°F Coolant, 250°F Oil

BHP	RPM	BSFC	BTU/MIN/BHP		% FUEL ENERGY		% BHP
			COOLANT	OIL	COOLANT	OIL	
180	2800	.424	16.0	5.0	12.1	3.8	49.5
170	2650	.422	16.2	4.7	12.3	3.6	49.2
160	2500	.420	16.1	4.8	12.3	3.7	49.3
150	2400	.420	16.4	4.8	12.5	3.7	50.0
140	2300	.419	16.6	5.0	12.7	3.8	50.7
100	1800	.417	17.8	5.1	13.7	3.9	53.8

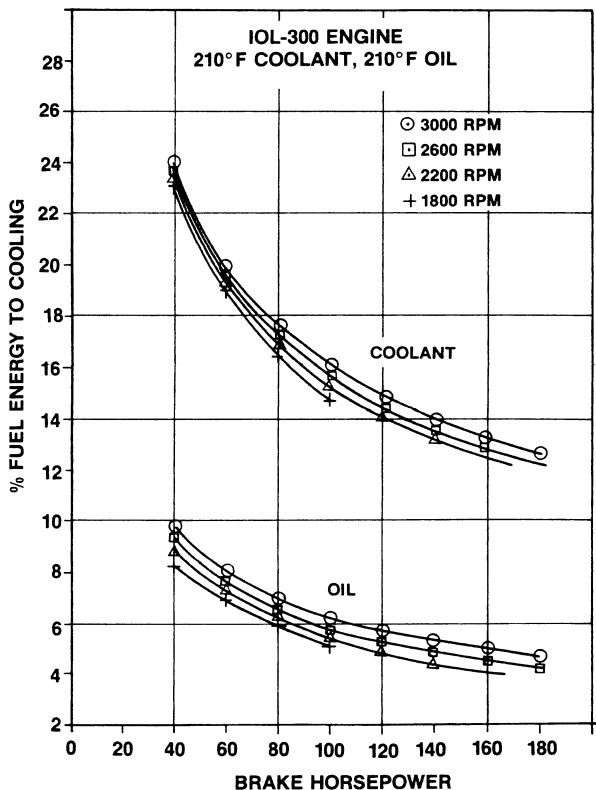

Fig. 18 - IOL300 Percent Fuel Energy to Cooling

A summary of IOL-200 engine heat rejection test results (total coolant and oil) along with an indication of cooling efficiency is presented in Table 1. The BHP's shown correspond to propeller load curve operation with 110 BHP being at 2750 RPM, best power mixture.

Figures 17 and 18 present heat rejection rates for the IOL-300 engine at best power mixture in terms of specific heat loss and percent of available fuel energy lost to cooling as a function of BHP and engine speed. The influence of speed and the resulting friction change on heat rejection is apparent. Coolant and oil heat losses are decreased 56% and 9-10%, respectively with an increase in temperature from 210°F to 250°F. Table 2 is a summary of IOL-300 heat rejection test results. BHP's shown correspond to a wide open throttle curve with 180 BHP being at 2800 RPM, best power mixture.

Engine heat rejected to coolant and oil at altitude is estimated to increase by 3-4% over the sea level values. This arises primarily as a result of the reduction in convection losses from the external surface area of the engine when operating in a low ambient density environment. Under test bed conditions with a conventional liquid cooled engine, typically 10-15% of fuel energy available is dissipated as radiation and convection losses to the ambient environment. A proportioning of these losses is summarized in Table 3. The change in exhaust manifold surface losses would be realized as higher exhaust gas energy.

Table 3 - Engine External Heat Losses

Heat Loss External Surface	Sea Level	High Altitude
Coolant Jacket	3.0%	0.6%
Oil System	1.5%	0.3%
Exhaust Manifold	7.5%	1.5%
	12.0%	2.4%

The Voyager 200 and 300 heat rejection characteristics were compared with other engines with consideration to efficiency of cooling. Figure 19 shows the range of heat loss to cooling for typical spark ignition engines as compiled by reference (5) with the IOL-200 and IOL-300 data points added for comparison. It was concluded that the measured heat rejection rates are accurate and consistent with characteristics of properly designed similar engines. Furthermore, it was concluded that the method of comparison represented by Figure 19 can serve as a useful tool in more accurately predicting the heat loss rates for new design larger engines. For example, this curve would indicate a heat loss in the 10-16% range for a 550 cu. in. turbocharged engine at 375 BHP with a .801 Lb/Sec Ft² gas flow/piston area.

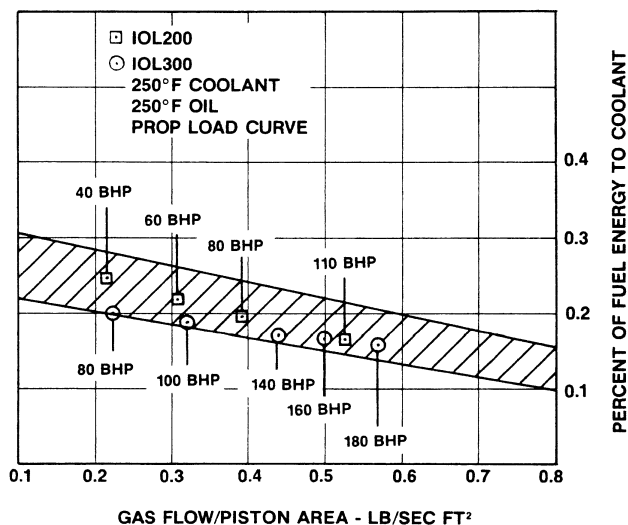

Fig. 19 - Engine Heat Loss to Coolant & Oil for Spark Ignition Engines

IMPROVED BREATHING

Intake and exhaust manifolds on both the 200 and 300 cubic inch engines were performance optimized for best volumetric efficiency. Computer simulations were performed to evaluate intake and exhaust manifold configurations. Effect of tube diameter and length, plenum volume, valve timing, and interference between cylinders was investigated for each system. The resulting intake manifolds as shown in Figures 5 and 6 are described as "spider" type manifolds with a

central plenum chamber to attenuate dynamic interference among the cylinders. The "spider" intake manifolds have been shown to provide improved fuel/air ratio distribution as compared to the "log" or "runner" type. An intake tube diameter of 1.15 inches was determined to be optimum for both engines. Volumetric efficiency characteristics are quite acceptable with best efficiency occurring near rated speed as shown in Figure 20.

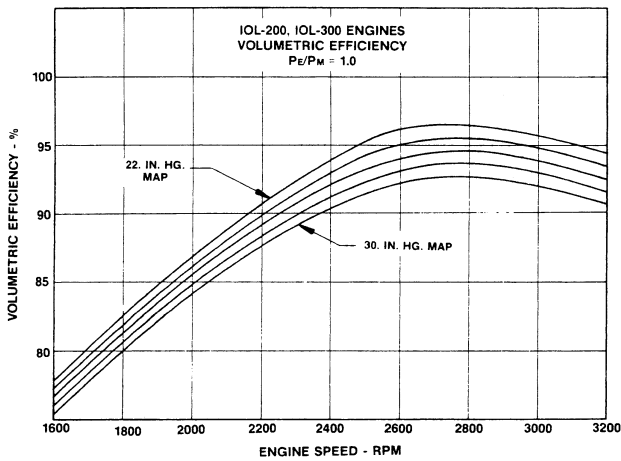

Fig. 20 - Volumetric Efficiency

The optimized exhaust manifold used with the prototype IOL-200 engine consisted of a system where the exhaust gases from each of the four cylinders were directed through individual ducts to a central plenum. This plenum along with the individual tube lengths was sized to promote scavenging and provide best tuning effect. The plenum also serves to attenuate pressure wave effect of one cylinder upon the other. The six cylinder exhaust manifold was similarly designed with the exhaust from each bank of three cylinders collected into separate plenums separated by a partition within the common header. Construction was 601 inconel with self sealing thermal expansion joints located in each of the 1.375 O.D. X .049 wall exhaust ducts.

INLET PORT FLOW BENCH TESTS

A flow bench assessment was performed prior to detail design of the cylinder head using a model of the inlet port. The model was developed to yield a flow coefficient significantly better than available with the equivalent air cooled head. The refined port was unrestrictive and was shown to provide an acceptable level of swirl for efficient combustion. Inside diameter of the intake valve seat was reduced from 1.58 in. to 1.42 in. in order to increase mean inlet gas velocity and provide higher volumetric efficiency in the cruise range. The flow area of the intake valve seat was also radiused for better flow characteristics.

The inlet port Mach Number index "Z", also called gulp factor, is used as an indication of the intake valve flow capacity and engine breathing efficiency. For minimum pumping losses and best volumetric efficiency, experience has shown that "Z" should not exceed 0.6, since volumetric efficiency drops rapidly beyond this point. Flow bench tests of both the original

and refined inlet ports are summarized in Table 4. A significant improvement in flow coefficient is obtained with the refined port. A gulp factor of .374 for the refined port as compared to .340 for the original port indicates the port is unrestrictive.

Table 4 - Inlet Port Flow Bench Test Results

	Swirl Ratio	Flow Max.	Coefficient Mean
Original Port	.49	.47	.32
Refined Port	.63	.62	.41

Design of the exhaust port has somewhat less effect on performance than the inlet port. The exhaust port is only required to be unrestrictive whereas the inlet port should impart an element of swirl to the charge flow. The exhaust port was redesigned consistent with good design practice to improve the flow characteristics. Exhaust valve diameter was reduced from 1.446 in. to 1.321 in.

PERFORMANCE

Engine BHP as a function of RPM and manifold pressure is presented by the performance maps, Figures 21 and 22.

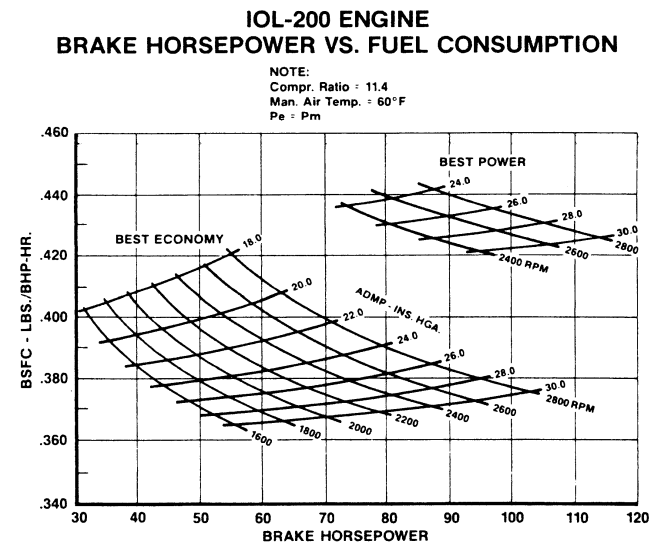

Fig. 21 - IOL200 Performance MAP

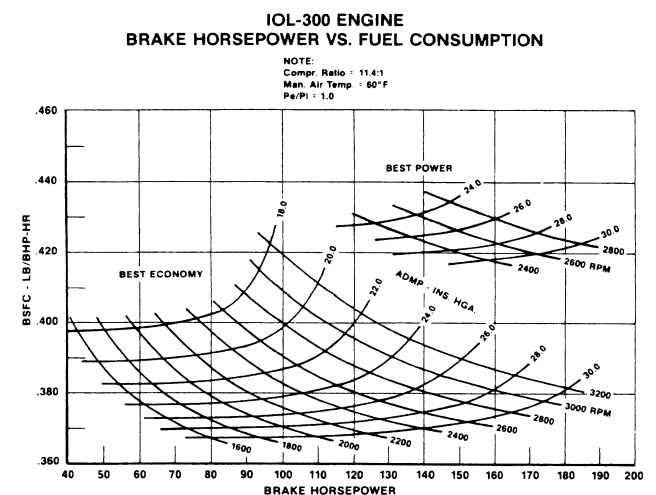

Fig. 22 - IOL300 Performance MAP

Brake thermal efficiencies demonstrated on the engine were quite good, reflecting the effectiveness of the 11.4:1 CR. Referring to Figure 23, a typical energy balance curve for 2450 RPM WOT shows a brake thermal efficiency of 36% with 21% of fuel energy lost to cooling at best economy fuel/air ratio. As cylinder pressure ratio P_M/P_E increases, even higher efficiencies are obtainable. The energy balance curve clearly demonstrates the dramatic effect fuel/air ratio has upon thermal efficiency and the large amount of energy remaining in the exhaust gas. Approximately 10-15% of the exhaust and unaccounted losses is associated with radiation and convection losses from external surface areas. This indicates about 28-33% of fuel energy remains in the exhaust gas at best economy fuel/air ratio.

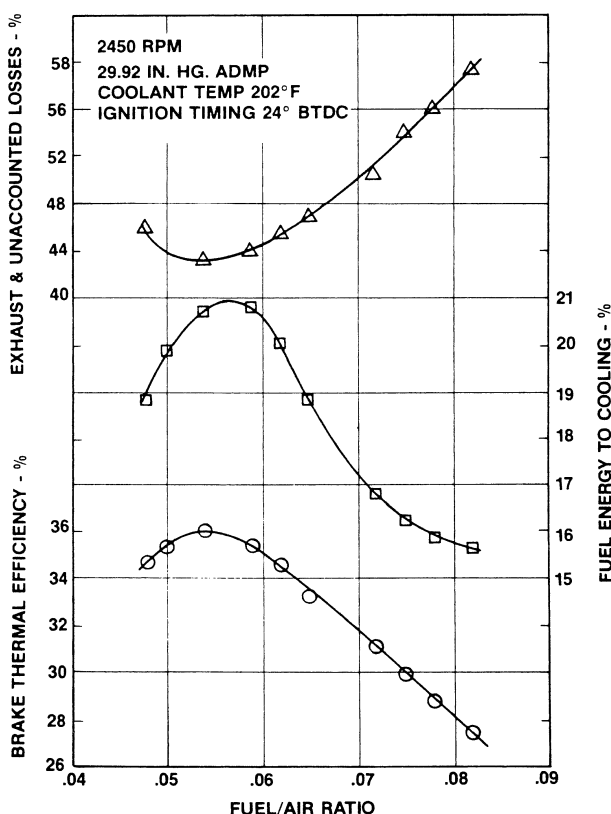

Fig. 23 - Energy Balance for IOL200 at 2450 RPM WOT

The IOL-200 engine is capable of being rated at 110 BHP (+5%, -0%) at 2750 RPM with a .425 BSFC at best power mixture. High speed testing yielded a maximum of 135 BHP at 3600 RPM; however, volumetric efficiency begins to drop after 2800 RPM and output becomes breathing limited beyond 3600 RPM. Takeoff speed for the 200 cubic inch engine in the Voyager aircraft was 3000 RPM, equivalent to 120-125 BHP. Revisions to valve timing, cam lift, and intake porting would be necessary for more efficient operation at the higher speeds. Typical performance rating for the IOL-300 is 170 BHP (+5%, -0%) at 2700 RPM WOT with a .425 BSFC at best power fuel/air ratio. As shown on the performance map, the engine is capable of producing 180-190 BHP at 2800-3000 RPM.

Tests were performed to investigate the effect of oil and coolant temperature changes on engine perform-

ance. Varying of oil and coolant inlet temperatures within the 180°-250°F range resulted in a negligible effect on engine output, the measured change being within 1%, with an indication that a lower coolant temperature tended to have a positive effect on BHP. Lower oil temperatures tended to represent a negative influence as would be expected due to the higher viscosity and increased friction losses. The effect of inlet air temperature on BHP was determined to be represented by the ratio of observed to standard day inlet air temperatures raised to the .75 power, equivalent to approximately 1% BHP change per 7°F.

An ignition timing survey was conducted on the IOL-200 engine from 18° to 30° BTC using conventional magneto ignition. Spark advance for best torque was established at 20-22° BTC with 26° BTC providing best SFC, these trends being consistent across the 1650-2750 RPM speed range. Engine knock was not encountered until the timing was advanced to 30° BTC. A spark timing of 24° BTC was selected as a compromise between mean best torque, best SFC, and cylinder firing pressure.

Spark advance requirements of the 300 cu. in. engine were investigated using an experimental capacitance discharge solid state ignition system. It was found that ignition timing for best fuel economy occurred at approximately 24° BTC for 1600-2800 RPM. Timing advanced beyond 24° offer no improvement in SFC. Best torque was obtained at a spark advance of 17°-19° BTC. Settings within +3.5% of MBT timing result in a BHP loss of less than 2%. If necessary to use ignition timing for knock control, a setting of 13° BTDC could be used without a significant loss of BHP. It was concluded that optimum timing was relatively insensitive to engine speed.

FUEL CONSUMPTION

Specific fuel consumption characteristics are well below the levels achieved on most similar engines and are equivalent to SFC characteristics of some diesel engines. The basic engine is capable of a best economy ISFC of .322 Lbs/IHP/Hr at an .055 fuel/air ratio. This corresponds to an observed specific fuel consumption of .375 Lbs/BHP/Hr when leaned at wide open throttle and max speed. The engines are rated at maximum power using best power mixture which is equivalent to a .425 BSFC at 2750 RPM.

As illustrated by the engine performance maps, Figures 21 and 22, the engines have a wide operating range in which low fuel consumption levels can be obtained. The BSFC trends shown represent minimum fuel consumption, referred to as best economy mixture, which occurs at approximately an .055 fuel/air ratio. Best power mixture occurs at .070-.075 F/A with peak EGT at .063-.067 F/A. Typical mixture loops for the four and six cylinder engines are shown as Figures 24 and 25. As seen on these curves, cylinder mixture distribution is very good as evident by the individual cylinder EGT's peaking at approximately the same fuel/air ratio.

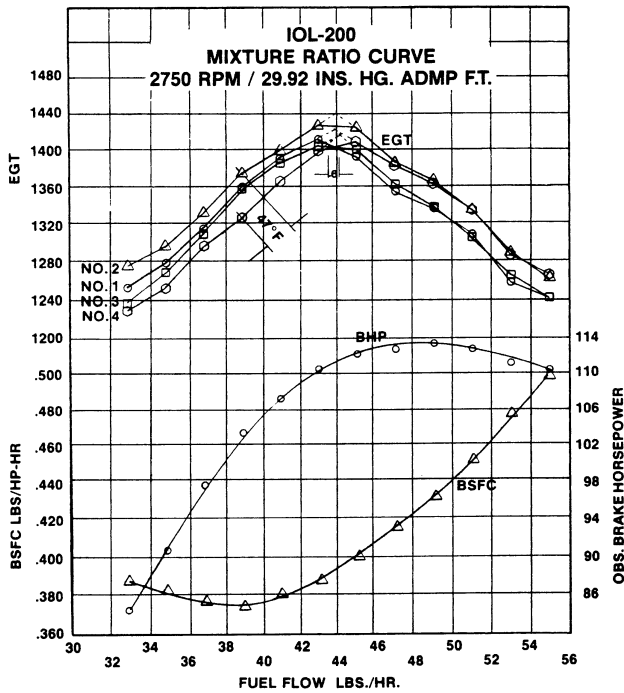

Fig. 24 - Mixture Curve, IOL200 at 2750 RPM, WOT

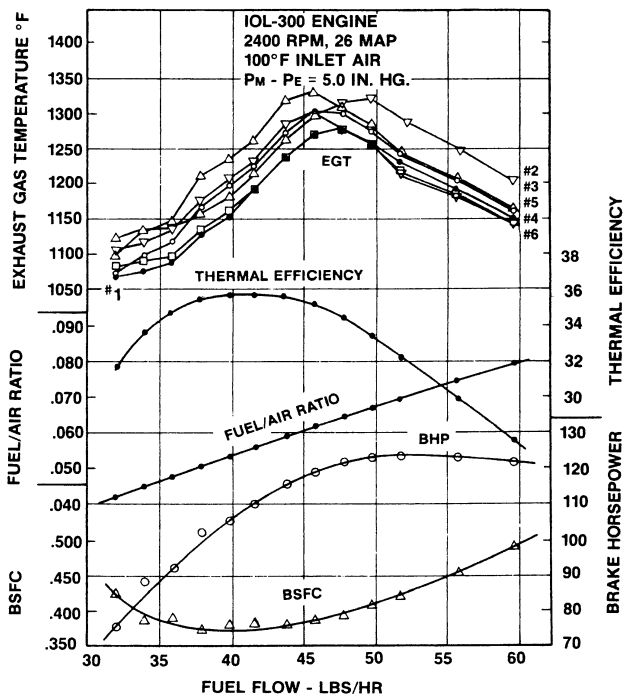

Fig. 25 - Mixture Curve, IOL300 at 2450 RPM, 26 MAP

Defining cylinder exhaust pressure as P_E and intake manifold pressure as P_M , all performance data is qualified for specific conditions of cylinder pressure ratio P_E / P_M . As P_M exceeds P_E , BHP and BSFC tend to improve while knock tendency decreases. Significant performance improvements are possible with lower P_E / P_M ratios as would be obtainable with more efficient turbines when turbocharging at high altitude. The effect of P_E / P_M on IHP and ISFC is illustrated by Figure 26. Simulating such turbocharging by controlling $P_M - P_E$ to 10 in. Hg., a .345 BSFC, was demonstrated on the 300 cu. in. engine at 1600 RPM and 71 BHP as shown in Figure 27. This is clearly indicative of the ultimate potential of this engine concept. Mixture

loops at higher engine speeds are presented in Figure 28.

The record breaking nonstop, non-refueled flight around the world by the Voyager aircraft is exemplary of the low SFC capability of the IOL-200. This flight would not have been possible using conventional air cooled low compression ratio engines with a 20% higher SFC rate. Only 18.3 gallons remained in the fuel tanks after completion of the 216 hour flight which consumed 1208.9 gallons.

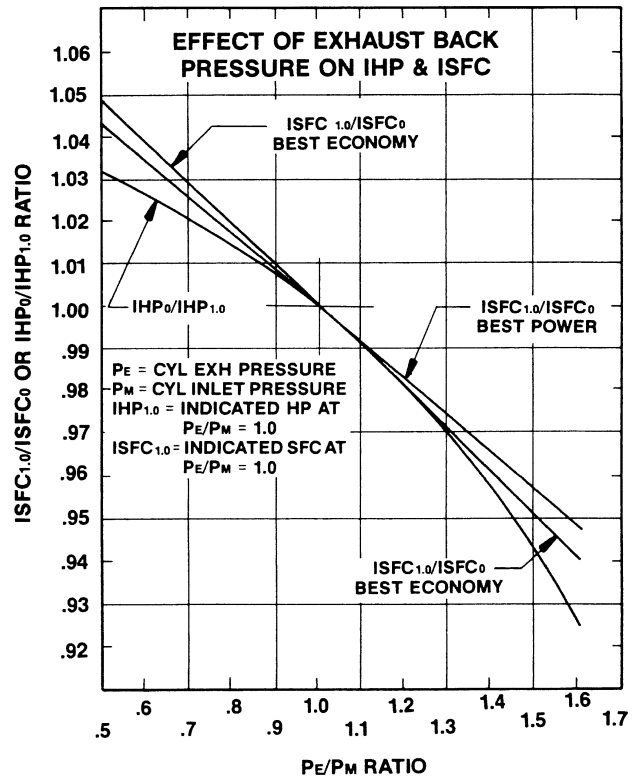

Fig. 26 - Effect of Exhaust Back Pressure on Indicated HP and SFC

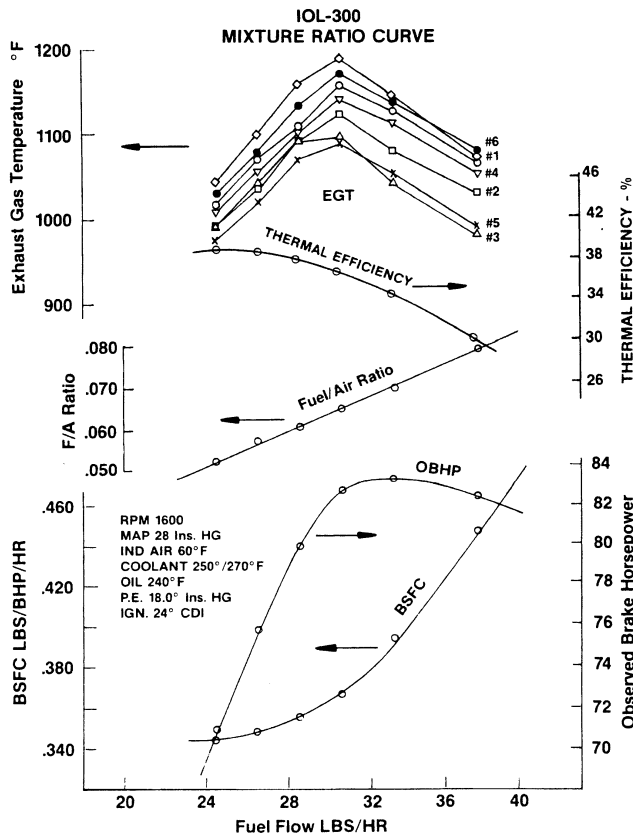

Fig. 27 - IOL300 Mixture Curve at 1600 RPM, PM-PE = 10 In. HG

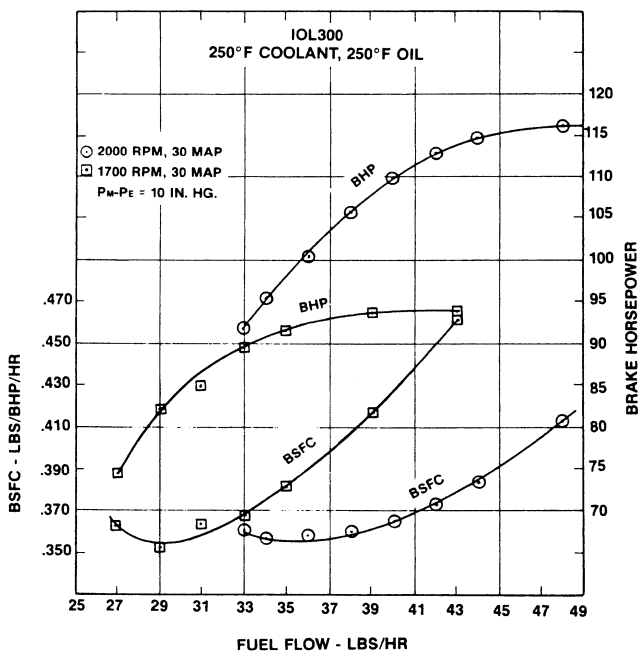

Fig. 28 - IOL300 Mixture Loops

OIL CONSUMPTION

Brake specific oil consumption (BSOC) is defined as the ratio of oil consumed to engine power, the units being Lbs/Hr/BHP. The best air cooled aircraft engines produced for general aviation typically provide a .001-.002 BSOC. Oil consumption rates for the liquid cooled IOL-200 and IOL-300 were demonstrated to be as good or better than the air cooled equivalent. Normally, the hardened steel cylinder barrel as used in

the prototype liquid cooled engines does not yield as Iowan oil consumption as the nitrided barrels used in the higher output air cooled engine. However, with refinements to the cylinder bore finish and bottom piston ring, BSOC improvements were obtained. Typical oil consumption test values for the 300 cu. in. engine are summarized in Table 5. In comparison, the WWII vintage liquid cooled Allison V-1710 was rated at .010-.015 BSOC at maximum power, equivalent to 14 Qts/Hr.

Table 5 - IOL-300 Oil Consumption test Results

BHP	RPM	EQUIVALENT	
		BSOC	HRS/QT
148	2600	.0011	11
136	2400	.0011	12
101	2000	.0011	16
81	1800	.0003	74
70	1700	.0002	129

ENGINE WEIGHT

The Voyager engine development program has shown that it is possible to provide a liquid cooled engine with a dry weight same as the equivalent air cooled engine. A weight difference arises due only to the bulk coolant volume; specific weight of 60/40 ethylene glycol is 9 Lbs/Gal at 60°F. However, this additional weight can be negated or minimized with reduced cooling drag, since a well design coolant to air heat exchanger, which is a more efficient heat transfer device than the finned multi-cylinder air cooled engine, requires substantially less cooling airflow.

Weight of the 4.06 in. bore liquid cooled cylinder assembly is 1.5 lbs lighter than the air cooled equivalent. This weight advantage becomes more significant as the bore size increases with a liquid cooled 5.25 in. bore cylinder 3.5 lbs lighter. The weight savings achieved with the lighter cylinder along with removal of inter-cylinder and cowling perimeter baffles tends to offset the additional weight associated with heat exchanger, coolant pump, coolant plumbing, and expansion reservoir.

Table 6 presents a weight summary for the technology demonstrator engines. Further weight reduction is possible with adaptation of lightweight techniques. Weight of coolant within the cylinder heads and manifolds is 6.4 lbs and 8.8 lbs for the IOL-200 and IOL 300, respectively. Size and weight of the coolant to air heat exchanger are application dependent. Aircraft considerations such as takeoff speed, max altitude, and heat exchanger location directly influence design of this heat sink. Weight for an optimized coolant heat exchanger is estimated at 6 lbs and 9 lbs, respectively, for the IOL-200 and 300 engines.

Table 6 - Engine Weight Summary

	IOL-200	IOL-300
Bare Engine	165.5	259.0
Intake Manifold	6.7	7.8
Fuel System	5.2	6.2
Magnetos, Harness	13.9	14.5
Spark Plugs	1.8	3.2
Coolant Manifolds	2.9	4.3
Coolant Pump	2.7	2.7
Starter Adapter	6.5	6.5
Starter Motor, 24V	14.5	14.5
Dry Wgt (Lbs)	219.7	318.7

ADVANTAGES, LIQUID COOLING

The lightweight approach to liquid cooling the power section in combination with the efficient weight effective brazed aluminum plate/fin type heat exchangers now available are significant factors in allowing the liquid cooled engine concept described herein to provide an efficient weight competitive option to the conventional air cooled engine. The high compression ratio HTCC combustion chamber supplements the attractiveness of the Voyager 200 and 300 by providing improved thermal efficiency with substantial fuel savings.

Success of the high compression ratio high turbulence combustion chamber in the Voyager 200 and 300 engines is a classic example of the advantages offered with liquid cooling. By itself, liquid cooling does not necessarily provide improved fuel consumption; however, as demonstrated in this program, it can serve as the tool which allows engine refinements previously not possible with air cooling. Past attempts at incorporating HTCC into an air cooled general aviation engine were not as successful, largely due to the higher cylinder head metal temperatures. This earlier work had indicated that substantial improvements in cylinder cooling would be required for acceptable HTCC operation. Liquid cooling became the solution to this problem.

A further reduction in SFC is made possible during takeoff and climb operation. Most air cooled engines are rated at a mixture strength richer than best power mixture in order to provide a fuel cooling effect during the low speed takeoff and climb. It is not uncommon to encounter a .700 BSFC on the larger air cooled turbocharged engines. The typical turbocharged air cooled engine would overheat at a best power fuel/air ratio during takeoff and climb. Liquid cooling allows the engine to be rated at best power mixture since the cylinder assembly is designed to cool adequately under these conditions with proper sizing of the liquid to air heat exchanger. The Voyager 200 and 300 are rated at a .425 BSFC, representing a 25% reduction in takeoff and climb BSFC. Rating at best power mixture equates to a lower manifold pressure and reduced

peak cylinder firing pressure on turbocharged engines which assists in improved durability.

Liquid cooling also offers the potential for increased power output and improved detonation margin. The cooler combustion chamber provides improved knock resistance and allows an increase in compression ratio. Higher boost levels are feasible for turbocharged engines.

The conventional air cooled engine is well known for its cooling anomalies. It is not uncommon to encounter a large spread in cylinder head temperature (CHT) among the cylinders. Non-uniform cooling airflow distribution within the nacelle and the leakage associated with intercylinder and perimeter baffles are contributing factors. In addition, due to the nature of the air cooled cylinder design, it is usually difficult to achieve uniform cooling around the circumference of the head and barrel using the typical sheet metal baffles. Furthermore, the cylinder head metal temps may run 50-100°F hotter than obtainable on a liquid cooled design.

As illustrated by the cylinder assembly thermal maps of Figures 10 and 11, liquid cooling provides substantial improvements in cylinder cooling with more uniform temperature distributions in both the head and barrel areas. These temperature characteristics yield less distortion of the cylinder walls and better material strengths which result in lower wear rate and longer engine life. Uniformity of the temperatures around the circumference of the cylinder barrel is improved sufficiently to allow a reduced piston-to-cylinder running clearance as compared to the air cooled equivalent. Inherent with the basic concept of liquid cooling, the uniformity of cooling among the various cylinders on a given engine is now more finitely controlled and not subject to the variables which trouble the air cooled engines. The spread in individual cylinder head temperatures is reduced to approximately 40°F or less. With liquid cooling the engine manufacturer is able to effectively maintain control of engine cooling over its life span.

Significant reductions in cooling drag are also possible with the liquid cooled engine. Comparative analysis indicates that a 30%-50% reduction in cooling air mass flow is possible for the higher output engines using a well designed and properly installed liquid to air heat exchanger. The lower cooling drag will yield higher aircraft flight speeds or reduced fuel consumption for fixed flight speed. For example, a 50% reduction in cooling airflow equates to a 2-3% increase in forward speed or optionally a 7-10% decrease in BSFC and BHP required, assuming cooling drag at 15-20% of total aircraft drag. In a typical air cooled aircraft engine installation, the cooling air leakage around the perimeter and intercylinder baffles may approach 40% of the cooling airflow required for a new tightly baffled engine (6). The leakage around a properly installed single heat exchanger should be negligible. Fundamentally, a well designed heat exchanger is a far more efficient heat transfer device than the typical air cooled engine.

With the more uniform cylinder cooling, cooler combustion chamber temperatures, absence of cooling anomalies, and better wear characteristics, significant improvements in engine durability are now attainable. It is projected that these improvements will result in a more reliable highly efficient engine with longer TBO and reduced operating/maintenance costs. In addition, performance and operational advantages such as reduced SFC, increased power output, better detonation margins, greater tolerance to operational abuse, less severe cooling transients, and reduced cooling drag, contribute to provide an advanced aircraft engine concept capable of meeting the challenges of future general aviation requirements.

CONCLUSIONS

Results of the Voyager engine technology demonstration program have clearly demonstrated the feasibility and advantages of this unique liquid cooled aircraft engine concept. The basic design concept, performance, cooling and durability characteristics have been validated by a comprehensive test and development program which has accumulated well over 5500 hours test time to date.

It is concluded that liquid cooling offers definite advantages over air cooling in the areas of durability and performance. Other advantages such as lower operating costs and operational improvements are more subjective and can only be substantiated with service experience. These advantages and benefits are summarized as follows.

- More uniform cylinder cooling
- Cooler combustion chamber metal temperatures
- Absence of cooling airflow anomalies
- Better cylinder wear characteristics
- Improved durability
- Reduced fuel consumption
- Increased power output
- Better detonation margin
- Significant reduction in cooling drag
- Longer life and TBO
- Precise cooling control over engine life
- Greater tolerance to operational abuse
- Less severe cooling transients

ACKNOWLEDGEMENTS

The author would like to thank the management of Teledyne Continental Motors Aircraft Products Division for permission to publish this paper. In addition, the following individuals should be acknowledged for their valuable contribution to the successful development of the Voyager engine concept: R. Allen, W. Brogdon, T. Edelmayer, B. Estes, R. LaFollette, D. Mayrose, N. Schweitz, J. South.

REFERENCES

1. Herschel Smith, "Aircraft Piston Engines", McGraw-Hill Book Company, 1981.
2. M. T. Overington and R. H. Thring, "Gasoline Engine combustion - Turbulence and the Combustion Chamber", SAE Paper 810017.
3. James N. Mattavi, "The Attributes of Fast Burning Rates in Engines", SAE Paper 800920.
4. R. H. Thring and M.T. Overington, "Gasoline Engine Combustion - The High Ratio Compact Chamber", SAE Paper 820166.
5. Charles Fayette Taylor, "The Internal Combustion Engine in Theory and Practice", Volume I, The M.I.T. Press, 1982.
6. S. J. Miley, E. J. Cross, Jr., N. A. Ghomi, P. D. Bridges, "Determination of Cooling Air Mass Flow for Horizontally Opposed Aircraft Engine", SAE Paper 790609.