

# Review of Liquid-Cooled Aircraft Engine Installation Aerodynamics

S. J. Miley\*

Texas A&M University, College Station, Texas

The aerodynamic behavior of liquid-cooled aircraft engine cooling installations is reviewed. Design considerations for inlets, diffusers, and exits are discussed. It is shown that the design of an efficient liquid-cooled installation is a technically sophisticated problem. This problem should not be underestimated in the development program of liquid-cooled aircraft engines. Questions are raised concerning the availability of suitable radiators for aircraft installations.

## INTRODUCTION

To many, liquid-cooled aircraft engines seem to have an aura, a fascination that has not been given to air-cooled engines. Some of this is certainly due to aesthetics. Liquid-cooled engines are synonymous with streamlining and aerodynamically clean profiles. The connection is readily made to the legendary Spitfire, Mustang, and Messerschmitt. The unappealing radial-air cooled engine does not enjoy this subjective attribute. Today's horizontally-opposed air-cooled engines fare no better. The mention of liquid-cooling immediately stimulates designers to visualizing low-drag shapes and improved performance, and stimulates marketing to thinking in terms of lightning-bolt and shark-mouth paint schemes. However, if more objective criteria are applied, the air-cooled engine compares more favorably with the liquid-cooled engine.

It is apparent from literature during the 1930s period that each had strong proponents and that it was relatively easy to start an argument over the relative merits of each. Most of the same technical points apply today. The author, though, will separate these points into propulsion concerns and aerodynamic design concerns. From the standpoint of propulsion, the liquid-cooled engine offers better fuel efficiency and longer engine life. Better control of cooling paths and subsequently of component cooling is realizable. On the other hand, the air-cooled engine offers system simplicity and is less vulnerable to system component failure. The weight of the cooling system is less. From the standpoint of external aerodynamic design, the liquid-cooled engine offers reduced frontal area and the potential for reduced drag, particularly compressibility drag. The internal combustion engine aircraft speed record was held by a liquid-cooled engine; however, it is now held by a radial air-cooled engine. Engine power must be factored into the comparison. Ground cooling is more of a problem for liquid-cooled engines. From the standpoint of internal aerodynamic design, the liquid-cooled engine has a definite advantage. Aerodynamically, each component of the system is in theory well behaved, i.e., no separated flows. The liquid-cooling system is more tractable to analytical aerodynamic modeling and design. The horizontally-opposed air-cooled engine configuration leads to large separated flows, because the relatively large internal volumes and ducting necessary to do otherwise are not practical. This is inherent in the geometry of the engine. The radial air-cooled engine configuration is aerodynamically much easier to deal with.

Liquid-cooled aircraft engines are presently available up to approximately 400 hp. There are developmental programs under way that could extend this range. In some cases, these are derivatives of automobile engines; in other cases, these are unique designs, such as the rotary type. The author's recent experience with one of these

programs has brought forward an appreciation for the level of technology required to design an effective and efficient liquid-cooled installation. The technical problem of achieving the required cooling for minimum drag penalty should not be underestimated. It is the purpose of this paper to identify and discuss the various design problems of a liquid-cooled installation, indicating, where possible, what is known and what is unknown. Much of the information in this paper is taken from literature, particularly the works of Kuchemann and Weber.

## BACKGROUND

The first technical problem one encounters in aircraft liquid-cooling systems is the lack of current information. The state of the art is World War II, and this is where one must look for technical guidance. Immediately it is seen that there is very little available. The United States was far more successful in the development of air-cooled engines than liquid-cooled, and this is reflected in the literature. Success here is defined in terms of military requirements rather than civilian commercial requirements. The U.S. did produce liquid-cooled engine powered aircraft, but the engines were deficient in altitude performance in the European theater compared to their British and German counterparts.

Presently there are only three practical sources of information: the NASA Langley Research Center Technical Library, the Library of Congress, and the National Air and Space Museum. The key to building a data base in this area is to concentrate on foreign technology, principally German. What remains of the American developed technology is covered by the NACA indices. The few other documents that remain from industry and military programs can be found at the NASA library. The foreign programs of interest are the British and German efforts. Much of the British activity is inaccessible from the United States. While references to British documents are available at the NASA library, a large number of these still carry World War II classified status. Up to this point, there has been no reliable mechanism for determining which have been declassified by the British government; consequently, the WW II classified status is still in effect, and these documents are unavailable. There are two sources of German work, the National Technical Information Service (NTIS) and the "Operation Paper Clip" (OPC) collection at the National Air and Space Museum. There were numerous copies of the OPC collection available after World War II, but the only remaining one to the author's knowledge is in the Air and Space Museum. Concerning German work, the OPC collection is by far the most extensive, containing in excess of 500 documents. The NTIS holdings are less but contain more English translations. Copies of NTIS documents can be obtained from the PB Copy Center at the Library of Congress. A significant part of the German data concern radiator design and testing. The remainder deal with internal/external aerodynamics. A representative summary of the German work in installation aerodynamics can be found in Kuchemann and Weber<sup>1,2</sup> and Hoerner.<sup>3</sup> Regarding Refs. 1-3, they are considered essential by the author if one is to be effective in this area. Kuchemann and Weber provide the basics of the analytical modeling of the various aerodynamic components. Hoerner provides design information, much of it empirical, which is important not only for initial design cuts but also for

<sup>1</sup>Presented as Paper 86-2587 at the AIAA General Aviation Technology Conference, Anaheim, CA., Sept. 29-Oct. 1, 1986; received Nov. 12, 1986; revision received Aug. 22, 1987. Copyright (c) American Institute of Aeronautics and Astronautics, Inc., 1987. All rights reserved.

\*Associate Professor, Aerospace Engineering Department. Currently Guest Scientist, Institut für Entwurfsaerodynamik, DFVLR, Braunschweig, Federal Republic of Germany. Member AIAA.

important not only for initial design cuts but also for verification of computational models.

## INSTALLATION AERODYNAMICS

The prime component of the liquid-cooling system is the liquid/air heat exchanger or radiator. The purpose of the installation is to convey the required amount of cooling air mass flow to the radiator and then exhaust the heated air to the external flow. A simplified system is shown in Fig. 1.

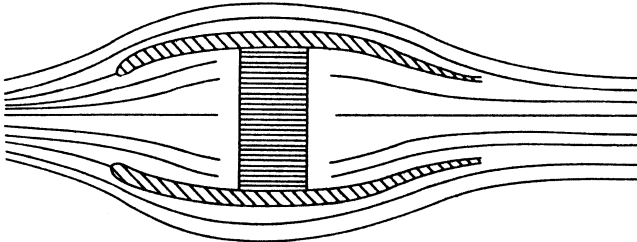

Fig. 1 Simple ducted radiator system.

Because of the velocity differential between the external free stream and that required by the radiator; the inlet area may be only 20 to 30 percent of the frontal area of the radiator. The aerodynamic components then consist of the inlet, the diffuser, the radiator, and the exit. Each of these components presents particular design problems that must be addressed if the system is to operate efficiently.

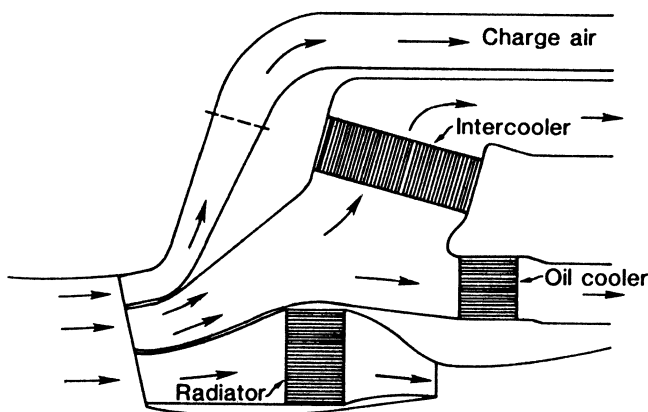

Fig. 2 Representative liquid-cooled aircraft engine cooling installation.

A representative liquid-cooling installation is shown in Fig. 2. Here a common inlet supplies three different radiators, each with different flow requirements and flow characteristics. Many times, restrictions on the available internal volume require slanting the radiators and/or ducting so that the airflow enters and leaves at oblique angles in relation to the radiator core passages. Figure 2 represents the "real world" design problem, as opposed to Fig. 1.

## INLETS

The aerodynamic operation of an inlet has some similarity to that of an airfoil. The lip contour and the locations of the stagnation point on the lip determine whether the inlet operates with attached flow or separated flow. This is illustrated in Figs. 3 and 4.

Consider first an airfoil; as the angle of attack increases in the positive direction, the stagnation point moves to the lower surface and the acceleration of the flow around the nose contour produces a suction pressure peak on the upper surface followed by an adverse pressure gradient that ultimately leads to separation. As the angle of attack increases in the negative direction, the stagnation point moves to the upper surface, resulting in a suction peak and ultimate separation on the lower surface.

In the case of an inlet, the inlet velocity ratio has a similar effect. Referring to Fig. 4, as the velocity ratio is decreased, the stagnation point moves to the inside of the inlet, producing a suction peak and possible separation on the outer surface. As the velocity ratio is in-

creased, the stagnation point moves to the outside, causing a suction peak and separation on the inner surface. Inlets with relative thick lip contours, like thicker airfoils, have a wider range of operation than those with thin contours.

The penalty is similar also in that thicker lip contours lead to increased frontal area and increased drag. A reasonable range of velocity ratios is

$$0.3 < V_i/V_0 < 0.7 \quad (1)$$

where  $V_i$  is the velocity at the inlet and  $V_0$  is the freestream velocity. Values outside this range would require special attention to inlet lip contour design. Relative changes in inlet velocity ratio for a liquid-cooled installation in a fighter aircraft due to altitude are shown in Fig. 5. The data are taken from Katzoff.<sup>4</sup>

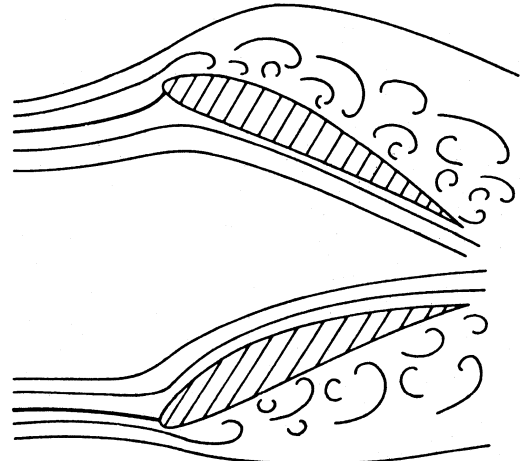

Fig. 3 Effect of stagnation point location on airfoil separation.

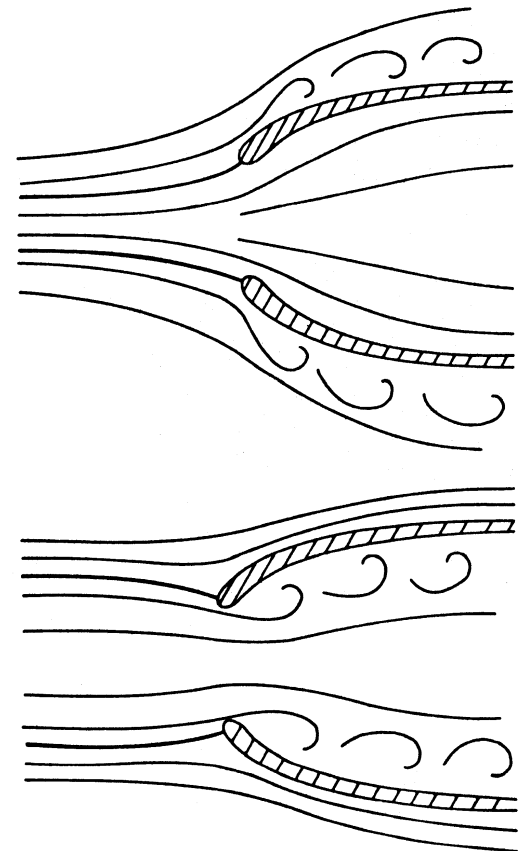

Fig. 4 Effect of stagnation point location on inlet separation.

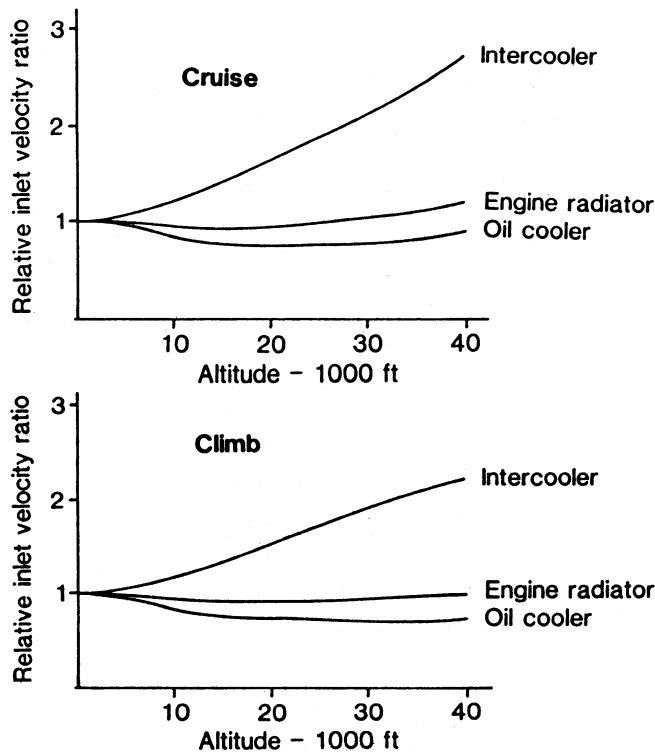

Fig. 5 Relative inlet velocity ratio as affected by altitude.

The curves were obtained by dividing the radiator-required volume flow by the aircraft true velocity. No information was given concerning the appropriate inlet area. The relative inlet velocity ratio differs from the actual value by a constant which is the reciprocal of the inlet area. For a given installed power, and thus the same cooling air mass flow requirement, the inlet area and therefore the constant will depend on the speed performance of the aircraft. A high-speed aircraft will require a smaller inlet area to pass the necessary mass flow, whereas a low-speed aircraft will require a larger inlet area to pass the mass flow. The issue in Fig. 5, however, is not the value of the constant but the change in the inlet velocity ratio that occurs over the performance envelope of the aircraft. It is seen in Fig. 5 that the engine and oil radiator-cooling air mass flow requirements result in a nearly constant inlet velocity ratio. The inlet(s) for these components could be optimized for a narrow range of operation. On the other hand, the intercooler radiator-cooling air mass flow requirements can alter the inlet velocity ratio by a factor of almost three. Referring to Eq. (1), this will exceed the normal good operating range of the inlet, and one now has an aerodynamic design problem to contend with. The heat rejection load on the intercooler increases with altitude because of the corresponding increase in pressure rise across the supercharger necessary to maintain a given power. Recent design analyses by the author for a liquid-cooled intercooler installation on a light twin-engine aircraft resulted in inlet velocity ratios in excess of 2 at 20,000 ft altitude compared to sea level. This relatively wide range of inlet operation called for special attention to lip contour design.

When considering inlets, a distinction must be made between three-dimensional nose or underslung geometries and two-dimensional wing mounted geometries. Each geometry has its own particular aerodynamic behavior, and accordingly, the lip contours will be different. Care should be used when applying 3-D inlet lip contours to a 2-D inlet, and vice versa. The stagger or sweep of the inlet causes changes in the flow such that the forward lip velocity is reduced and the rearward lip velocity is increased. The lip pressure distributions change with the inlet angle of attack, according to the movement of the stagnation point. An increase in angle of attack moves the stagnation point to the inside on the upper lip and to the outside on the lower lip, increasing pressure peaks and the possibility of separation as previously discussed.

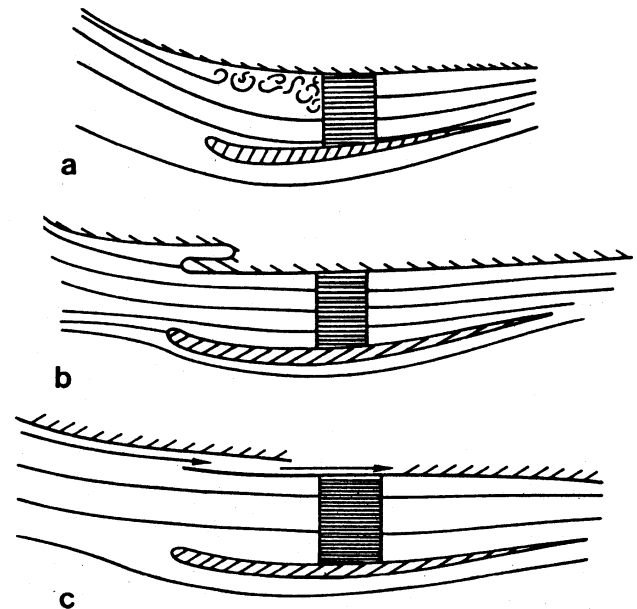

Fig. 6 Underslung inlet installation: a) airframe surface boundary-layer separation; b) offset from airframe boundary layer; and c) diversion of airframe boundary layer.

Care must be exercised in the use of underslung or protruding inlets. The aerodynamic behavior of 3-D or 2-D inlet depends on the lip geometry. If a fuselage or wing surface is used as one side of the inlet, the original inlet geometry is altered, and the flow over the lip contours may be different than planned. Design procedures for these types of inlets are given by Brodel<sup>5</sup> and Ruden.<sup>6</sup> The relatively thick boundary layer on the airframe surface often separates in the adverse pressure field of the inlet, reducing pressure recovery and increasing drag. This is illustrated in Fig. 6, along with current design solutions.

A summary of inlet design methodology is given by Kuchemann and Weber.<sup>7</sup> A bibliographic listing of inlet related technology is given by NACA.<sup>7</sup> It should be mentioned here that the analytical design procedures given in Ref. 1, 6, and 7, were developed prior to programmable computers. They use classic hydrodynamics formulations. They are amenable to digital programming, but one should have some knowledge of hydrodynamics before undertaking the task.

## RADIATORS

The operating theory of liquid/air exchangers will not be dealt with in this article. Interested readers are advised to consult Kays and London,<sup>8</sup> Fraas and Ozisik,<sup>9</sup> and the Military Vehicle Power Plant Cooling Handbook.<sup>10</sup> Aerodynamically, the radiator behaves as a orifice, causing a pressure drop in the duct which is a function of the flow velocity through the radiator. For a specific core configuration, the relationship between the flow velocity and the pressure drop is altitude-dependent, being primarily influenced by the air density. The pressure drop characteristics can often be represented by

$$w = a(\sigma_{ex} \Delta p)^b \quad (2)$$

where  $w$  is the cooling air mass flow,  $\text{Tex}$  is the density ratio of the heated air at the radiator exit, and  $\text{Op}$  is the static pressure drop through the radiator. The constants  $a$  and  $b$  depend on the core design. The selection of the radiator is the central problem of the cooling installation design. Given the operational heat rejection requirements, the selection problem is one of finding the optimum combination of radiator entry area and pressure drop characteristics. A large entry area results in low pressure drop and low internal drag; however, a large internal volume is required, or increased frontal area and high external drag will occur.

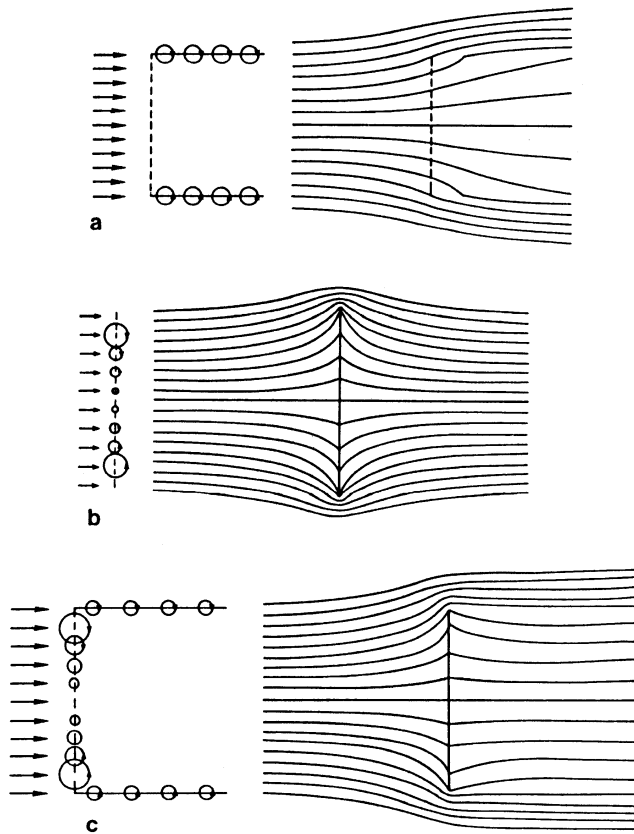

Fig. 7 Singularity models for development of streamline diffusers: a) vortices on bounding streamtube, b) vortices on radiator disk, and c) combined streamtube and radiator vortices.

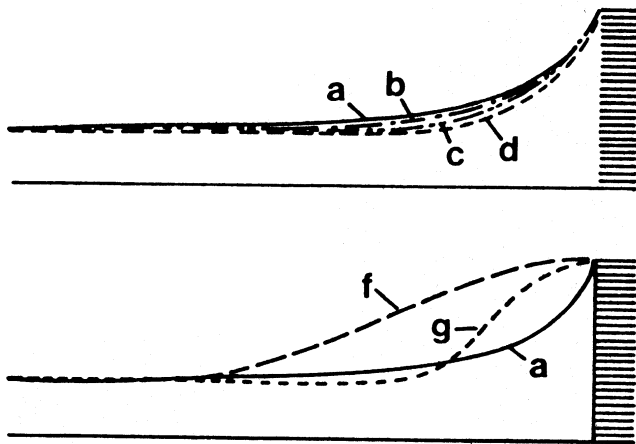

Fig. 8 Comparison of diffuser shapes listed in Table 1.

A small entry area leads to small volume requirements, reduced frontal area, and low external drag; high internal drag, however, results from the associated larger pressure drop. The question is further complicated by the availability of the thermal energy given to the air flow by the radiator. A part of this energy can be utilized to compensate for the increased pressure drop. There is often speculation that the imparted energy is sufficient to overcome the drag of the installation and produce a net thrust. The North American P-51 Mustang is said to have this attribute. The author, however, has uncovered no documentation to support this. The available literature on this subject (Refs. 2, and 11-14) is entirely theoretical and is divided between the British position (pro) and the American and German positions (con). The weight of opinion at present is against realizing a net thrust from the cooling installation.

As stated previously, a large amount of the German research activity was directed toward radiator development. There are a significant number of American publications in this area also. However, many of these are for air/air heat exchangers used as intercoolers for the air-cooled engines. In the author's opinion, an important obstacle to the application of

Table 1 Pressure drop for different diffuser contours<sup>2</sup>

Contour	$\Delta p/\Delta p_o$
(1) Streamline	1.08
(2) Exponential	1.28
(3) Circular arc	1.31
(4) Parabola	1.35
(5) Sine long	1.35
(6) Sine short	1.35

liquid-cooled engines to aircraft is the lack of suitable radiators. The term "suitable" here means radiators designed for operation at flight altitudes and having core geometries compatible with installation aerodynamic requirements. The radiators currently available are ground vehicle designs and are of the large entry area type. It is likely that useful radiators can be assembled from existing core structures; however, provision for this requirement should be incorporated into any liquid-cooled aircraft engine development program.

## INTERNAL FLOW AERODYNAMICS

Design problems with the internal flow ducting concern the use of diffusers, oblique flow entering and/or leaving the radiator, and the exit ducting. Diffusers are necessary to reduce the external air flow velocity to the level necessary for the radiator. Design methodology for diffusers is presented in Ref. 2 and data for different diffuser area ratios are given in Ref. 1. The design procedure simulates a freely exposed radiator block by a distribution of singularities. The singularity strengths are set by the ratio of the velocity at the radiator to that of the freestream. The bounding streamline that results provides the contour of the diffuser. As discussed in Ref. 2, it is necessary to employ the right combination of sources, sinks, and vortices to obtain a solution that will work in practice. The design procedure is illustrated in Fig. 7. Comparisons between the streamline contour and other contours are given in Table 1. The respective contours are shown in Fig. 8.

Often, it is necessary to achieve a reduction in the frontal area of the radiator installation. This is generally the result of limitation of available internal volume. The design problem is one of obtaining a trade-off balance between increased internal drag and increased external drag. Reducing the frontal area of a radiator is accomplished by slanting the radiator so that the entry and/or the exit flow is oblique to the core passages. The core matrix is thus required to function as a turning vane system. The ability to turn the flow is dependent on the leading edge radius of the core plates experiencing the angle of attack, i.e., the ability to support the necessary suction force. If elliptical or oval coolant passages are used in the core, these should be oriented to function as the turning vanes. Kuchemann and Weber<sup>1,2</sup> developed relations that give the upper and lower limits of the internal drag increment due to oblique flow. These are given as follows:

$$q = \Delta p_o/q + \tan^2 \alpha \quad (3)$$

$$q = \Delta p_o/q \quad \text{arc cos } (A_i/A_c) \\ q = \tan^2 \alpha \quad \text{arc cos } (A_i/A_c) \quad (4)$$

where  $\Delta p$  is the pressure drop due to the oblique flow,  $\Delta p_o$  is the pressure drop due to the normal flow,  $\alpha$  is the angle of attack of the flow, and  $A_i$  and  $A_o$  are the inlet and radiator areas as defined in Fig. 9. Equation (3) assumes flat plate behavior, i.e., no leading edge suction of the core elements, and represents the worst case. Equation (4) assumes some leading edge suction and is based upon experimental data. Results from Nichols<sup>15</sup> and Kuchemann and Weber<sup>2</sup> are given in Fig. 9. Equations (3) and (4) are identified in the figure. Higher oblique flow angles for the same drag penalty can be obtained by introducing stagger into the radiator design. The stagger angle effectively reduces the suction load on the core element for a given flow angle. Results from Ref. 2 showing the effect of the stagger angle are presented in Fig. 10.

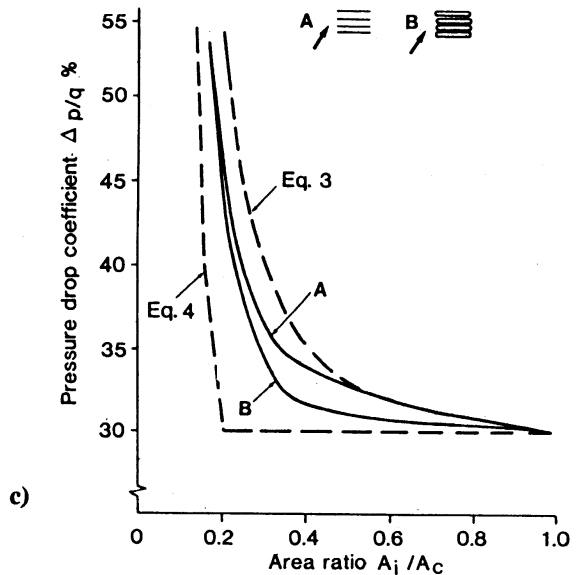
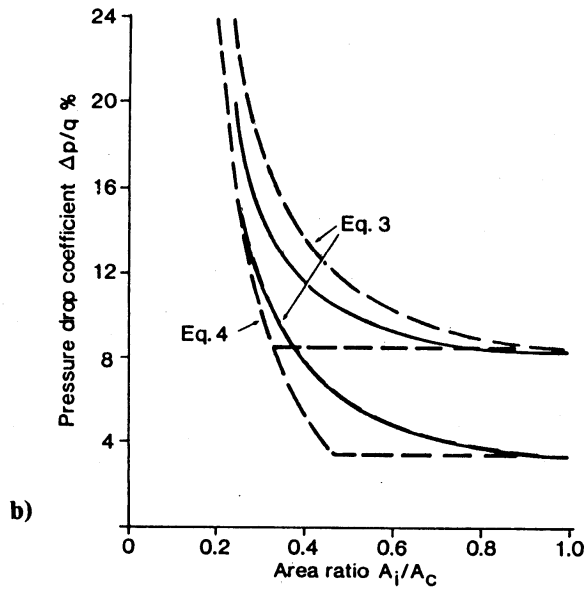
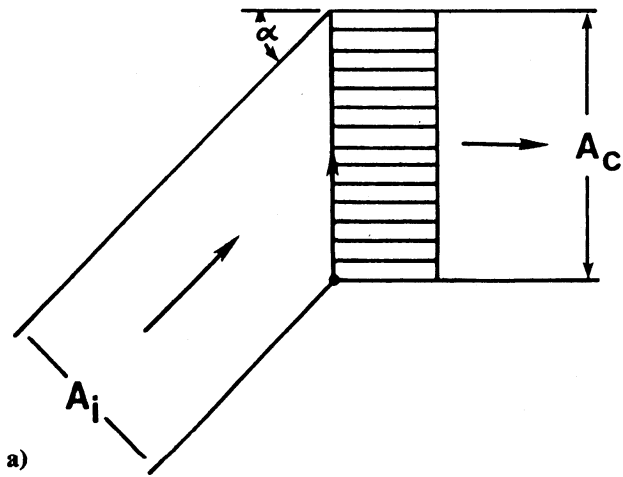

Fig. 9 Oblique flow effects: a) flow model, b) results from Ref. 2, and c) results from Ref. 15.

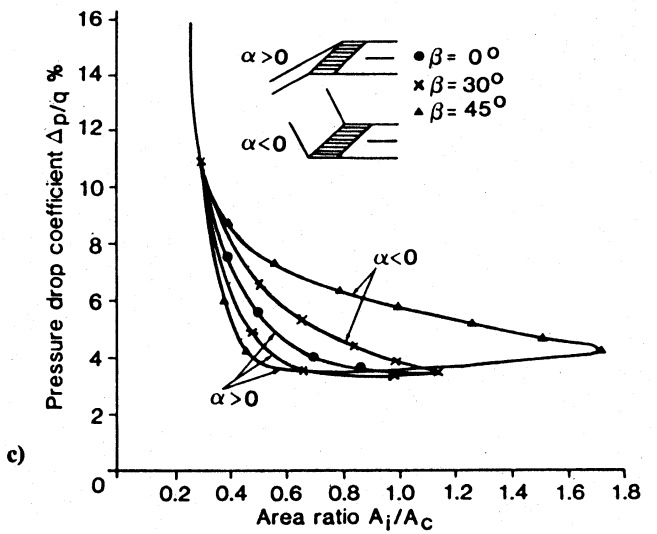
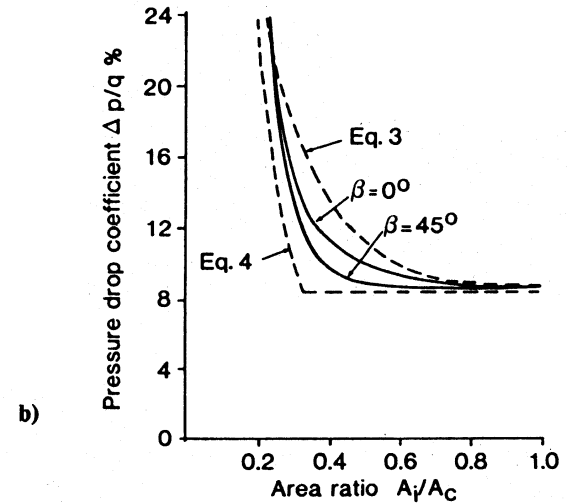
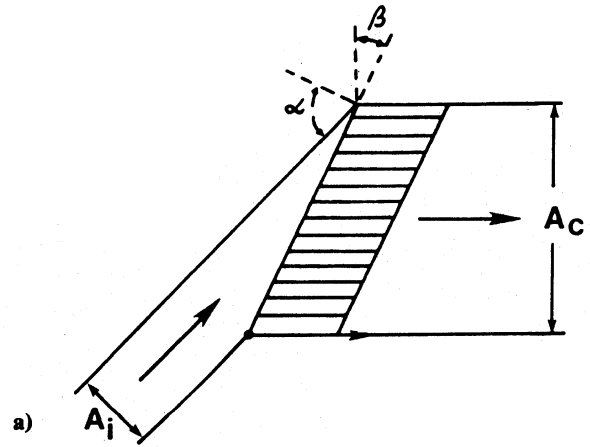

Fig. 10 Effects of staggered radiator on oblique flow: a) flow model, b) results from Ref. 2, and c) further results from Ref. 2.

The shape and angle of the exit duct also affects the pressure drop through the system. There are limits on the exit flow angle and distance to duct converging sections distance to duct converging sections, beyond which increases in internal drag occur.

## EXITS

The exit has two basic functions: to regulate the cooling air flow and to exhaust the cooling flow into the external flow so

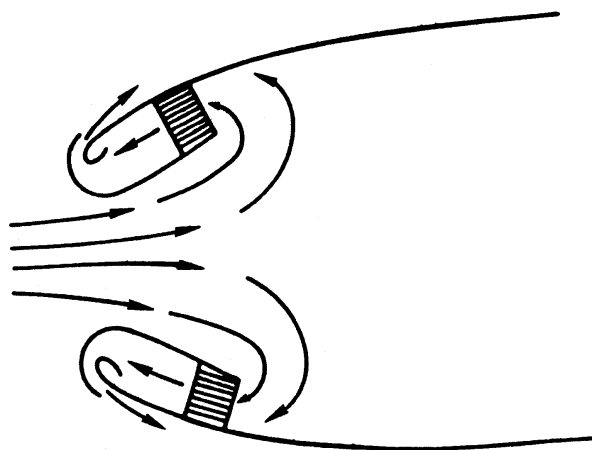

Fig. 11 Nose slot exit in asymmetric inlet cowl

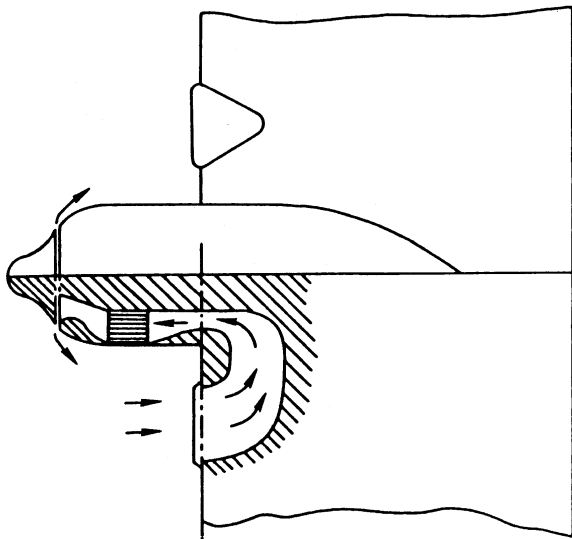

Fig. 12 Nose slot exit with wing leading edge inlets.

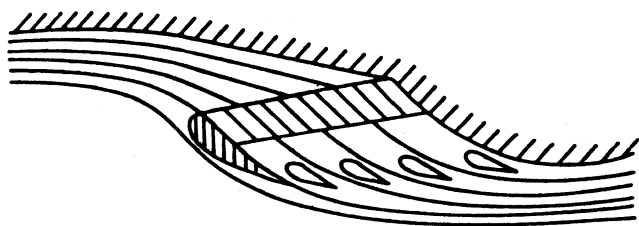

Fig. 13 Cascade exit flap.

as to result in minimal drag penalty. To adequately perform the regulation, the exit must act as both a throttle and a pump. Throttling is necessary in cruising flight to minimize the cooling drag by reducing the cooling flow to that sufficient to meet cooling requirements. In ground operation and in climbing flight, the exit must act as a pump to induce sufficient cooling flow through the system. Both of these functions can be performed by a hinged flap. The fundamental principle here is that for any subsonic flow system, the flow rate through the system will always adjust itself so that the static pressure at the exit will match the local external flow static pressure surrounding the exit. The static pressure at the exit is controlled by the exit area. Thus, regulation is obtained by varying this area. Opening the flap beyond the contour of the airframe creates a low-pressure region that induces additional flow through the system. It became common design practice during World War II to serve the exit flap to a coolant temperature sensor to optimize the system operation.

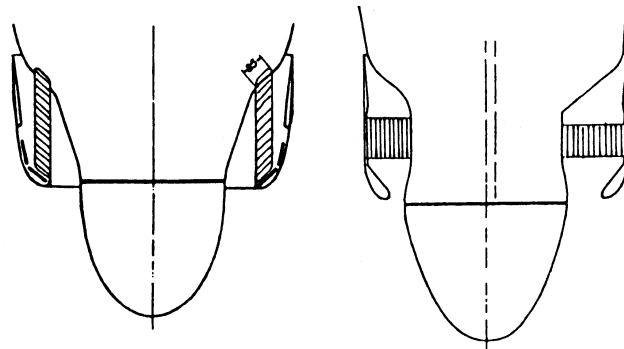

Fig. 14 Ring radiator installations

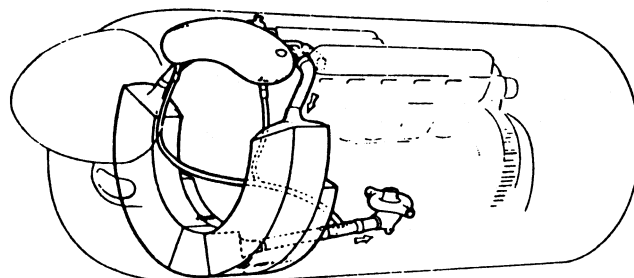

Fig. 15 Internal schematic ring radiator.

It is occasionally suggested that the cooling flow exits should be located in a low-pressure region on the aircraft to achieve extra pumping. Experimental results published by Hammen and Rowley<sup>16</sup> and by Miley et al.<sup>17</sup> show a net increase in drag for this approach. While cooling flow is increased, exhausting the flow into a low-pressure region leads to increased external friction drag and pressure drag due to subsequent flow separation. Another example of this is the nose-slot cowl developed by Merceir.<sup>18</sup> The cooling flow exit is located near the lip leading edge of an axisymmetric cowl where the suction peak occurs. Use is made of the suction peak to pump the cooling air. The cooling air inlet may be in the center of the cowl as in Fig. 11 or located elsewhere as in Fig. 12. Investigations by Smelt and Smith<sup>19</sup> and Theodorsen et al.<sup>20</sup> showed improved cooling in climb but an increase in drag for cruise and high-speed flight.

An interesting concept reported in Ref. 2 is the cascade exit flap shown in Fig. 13. Low pressure is generated through streamline curvature induced by the flap setting. No experimental data has been found by the author to evaluate this design.

## INSTALLATION DESIGN

There are many examples of installation designs in the cited references. In particular, Refs. 1-3 and 7 should be utilized. Two additional references in this category are Seddon and Harrison<sup>21</sup> and Harshorn and Nicholson.<sup>22</sup> However, supporting engineering data are not always given. Most of the designs fall into one of three types: fuselage underslung, wing underslung, and internal. Underslung installations locate the inlet, and in some cases the entire radiator system, on the lower surface of the aircraft. The location may be either on the fuselage or on the wing. The internal wing installations utilize two-dimensional leading edge inlets and locate the radiator within the thickness envelope of the wing section.

## RING RADIATOR INSTALLATIONS

Ring radiator installations have shown great promise. The inlet is in the nose of the cowl and can be axisymmetric. Two configurations are shown in Fig. 14, and an internal schematic is given in Fig. 15. The ring radiator offers advantages both from the standpoint of location and of design. Little if any increase in frontal area is required. The inlet design is less aerodynamically complicated, and pressure recovery with minimal losses is relatively easy to achieve. The installation is almost identical to that of radial air-cooled engines in appearance, and the design can benefit from this technology. The Focke-Wulf FW-190 fighter flew with both air-cooled and liquid-cooled engines. The ring radiator was utilized with the liquid-cooled installation. Examples of the ring radiator installation from Ref. 2 are given in Fig. 16.

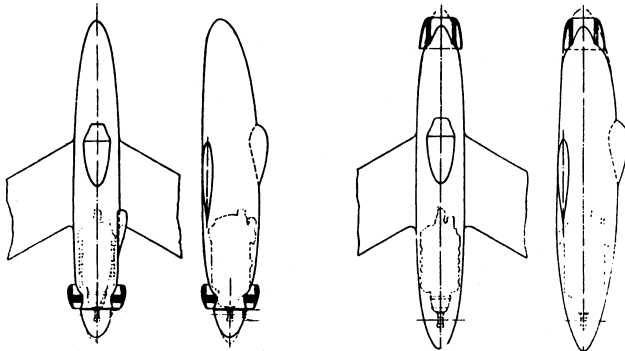

Fig. 16 Fore and aft ring radiator installations from Ref. 2.

## SUMMARY

Liquid-cooled aircraft engines are with us again. The current state of the art of installation aerodynamics has been reviewed in this paper. The level of technical sophistication required to do a good aerodynamic cooling installation should not be underestimated. The technical literature available is fragmented and sometimes difficult to obtain. However, most of the problems have been identified. The use of digital computers allow much more freedom in the development of analytical models. The one major area of concern is the availability of suitable radiators. There are still unanswered questions regarding large-frontal area/low-pressure drop vs small frontal-area/high-pressure drop. Retrofitting existing air-cooled installations forces consideration of the latter because of inadequate internal volume within the airframe.

## REFERENCES

- 1 Kuchemann, D. and Weber, J., *Aerodynamics of Propulsion*, McGraw-Hill, New York, 1953.
- 2 Kuchemann, D. and Weber, J., "Cooling," (AVA Monograph J1), British Ministry of Supply, Reports and Translations 914-923, 1946.
- 3 Hoerner, S.F., *Fluid-Dynamic Drag*, Hoerner Fluid Dynamics, Brick Town, NJ, 1965.
- 4 Katzoff, S., "High-Altitude Cooling, V-Cowling and Ducting," NACA Wartime Rept. L-775, 1945.
- 5 Brodel, W., "Theory of Plane, Symmetrical Intake Diffusers," NACA TM 1267, March 1950.
- 6 Ruden, P., "Two-Dimensional Symmetrical Inlets with External Compression," NACA TM 1279, March 1950.
- 7 Anon., "Bibliography of NACA and Other Reports on Air Inlets and Internal Flows," NACA Res. Memo. 8J05, Oct. 1948.
- 8 Kays, W.M. and London, A.L., *Compact Heat Exchangers*, McGraw-Hill, New York, 1964.
- 9 Fraas, A.P. and Ozisik, N.M., *Heat Exchanger Design*, Wiley, New York, 1965.

- 10 Anon., "Engineering Design Handbook-Military Vehicle Power Plant Cooling," US Army Material Command, AMCP 706-361, June 1975.
- 11 Meredith, F.W., "Note on the Cooling of Aircraft Engines with Special Reference to Ethylene Glycol Radiators Enclosed in Ducts," British ARC Repts and Memo. 1683, Aug. 1935.
- 12 Rauscher, M. and Phillips, W.H., "Propulsive Effects of Radiator and Exhaust Ducting," *Journal of the Aeronautical Sciences*, Vol. 8, Feb. 1941, pp. 167-174.
- 13 Winter, H., "Contributions to the Theory of the Heated Duct Radiator," NACA TM 893, April 1939.
- 14 Berton, A.B.P., "The Increase in Thrust Obtainable from a Power Plant Installation using the Cooling-Air as a Propulsive Jet," British ARC Repts and Memo. 2147, May 1945.
- 15 Nichols, M.R., "Investigation of Flow Through an Intercooler Set at Various Angles to the Supply Duct," NACA Wartime Rept. L408, 1945.
- 16 Hammen, T.F., Jr. and Rowley, W.H., "Factors Pertaining to Installation of Inverted In-Line Aircooled Aircraft Engines," *SAE Journal (Transactions)*, Vol. 54, March 1946, pp. 138-152.
- 17 Miley, S.J., Cross, E.J. Jr., Owens, J.K., and Lawrence, D.L., "An Experimental Investigation of the Aerodynamics and Cooling of a Horizontally-Opposed Air-Cooled Aircraft Engine Installation," NASA Contractor Rept. 3405, March 1981.
- 18 Mercier, P.E., "Drag and Cooling of Air-Cooled Engines," *Aeroplane*, Vol. 61, No. 1571-72, July 1941, pp. 21-22, 24, 48-50.
- 19 Smelt, R. and Smith, F., "Model Tests of a 'Return-Flow' Cooling Scheme, having a Wing Leading Entry and a Nose-Slot Exit," British ARC Repts and Memo. 2403, March 1940.
- 20 Theodorsen, T., Brevoort, M.J., Stickle, G.W., and Gough, M.N., "Full-Scale Tests of a New Type NACA Nose-Slot Cowling," NACA Rept. 595, 1937.
- 21 Seddon, J. and Harrison, J.E.A., "A Collection of Wind Tunnel Test Data on the Exit Static Pressures of Engine Cooling Ducts," RAE Rept. AERO 2127, March 1946.
- 22 Hartshorn, A.S. and Nicholson, L.F., "The Aerodynamics of the Cooling of Aircraft Reciprocating Engines," British ARC Repts and Memo. 2498, May 1947.